

8" Round Fan MODEL: 831C Series

If the installation presents a problem that is not explained here or if any parts of these instructions are not clear, consult a professional installer. If you are not familiar with methods of installing electrical wiring, or if you are not certain as to the correctness of any step or procedure described, secure the services of a qualified electrician.

INSTALLING THE HOUSING

- Cutout dimension: 9" diameter
- Blade Size: 8"
- Grille Diameter: 10½"

IMPORTANT: Remove shipping tape that secures louver.

1. Slide hanger bars (adjustable for 24" O.C. joists) through tabs in housing. Nail one hanger bar to joist and slide ventilator to desired position. Nail second hanger bar to joist: cocking it slightly to clamp fan into place.

Do not install in a ceiling insulated to a value greater than R-40.

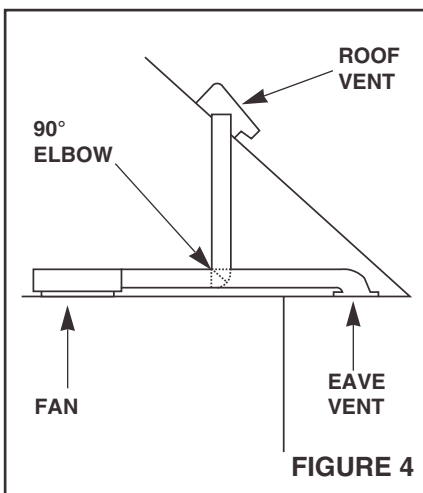

MAKING CONNECTIONS

IMPORTANT: Prior to making wiring connections, disconnect electrical power at the main source and leave it off until the installation is complete. All wiring must comply with electrical codes.

1. Refer to Figure 1. Place wiring into the outlet box. Secure the connections with approved wire connectors and replace the cover plate.
2. Refer to Figure 2. Run 120vAC wiring (with ground) from main source through wall switch to the fan location.
3. Using wire nuts, connect supply wires to fan wires as follows: black to black, white to white. Connect ground wire to green ground screw.
4. Use electrical tape to insulate all wire nut connections.
5. Replace junction box cover and secure with screw.
6. Refer to Figure 3. Install outside wall cap with flange against outside of brick or sheathing, allowing sufficient room around flange for caulking. Connect discharge opening in fan housing to outside wall cap with standard 3½" x 10" duct.
7. Refer to Figure 4. For vertical discharge installations, use elbow and 3¼" x 10" ductwork extended into roof cap.

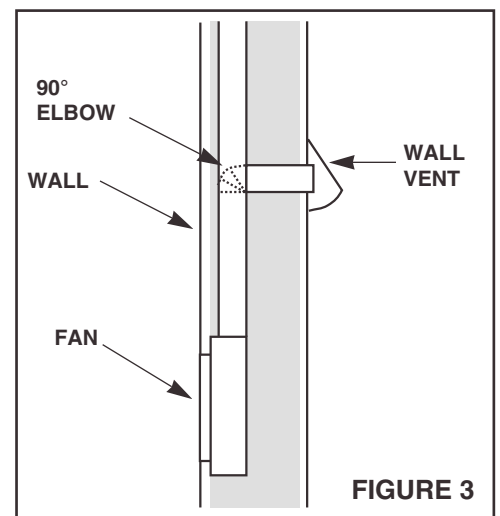
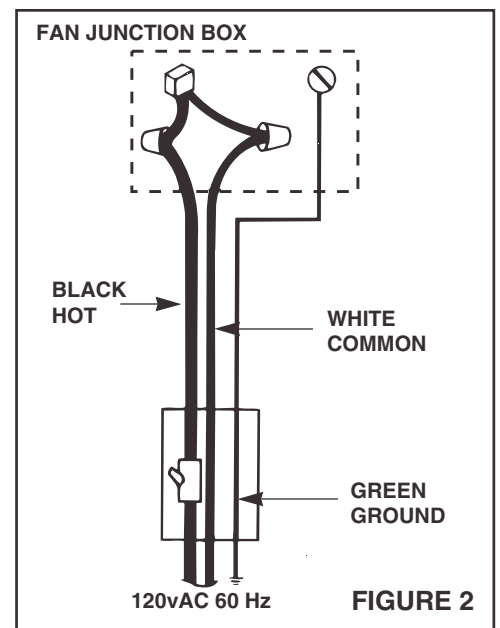
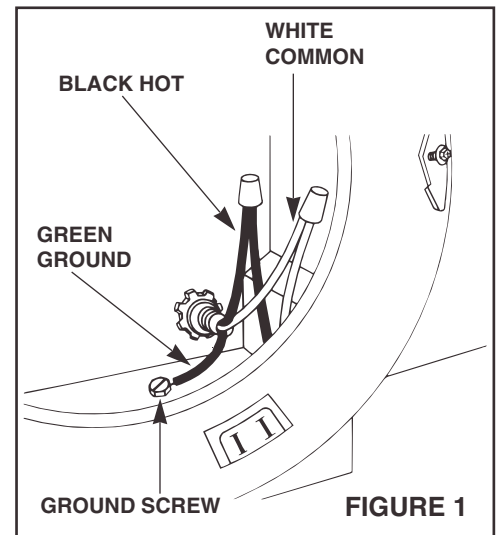

FINAL ASSEMBLY INSTRUCTIONS

1. Check louvers in fan housing and outside wall cap to see that they are not damaged or binding. Louvre can be readily removed by depressing spring bearings on end of hinge pins.

Refer to Figure 5. Install motor and blade assembly into housing. Be sure motor leads are toward receptacle. Plug motor lead into receptacle. Spin blade to be sure it turns freely.

2. Fasten grille in place with thumbscrew (furnished.)

BE SURE UNIT AND SWITCHES ARE PROPERLY GROUNDED AND ALL WIRING COMPLIES WITH LOCAL CODE REQUIREMENTS.

MAINTENANCE AND CLEANING

FILTER

To clean the filter (optional,) soak in hot, sudsy water. Rinse thoroughly and allow to dry.

GRILLE

Use only a mild soap and water solution to clean the grille. Do not use abrasive cleaners.

MAINTENANCE

Refer to Figure 6. Oil motor at least once a year. Use 4-5 drops of SAE 20 motor oil. Do not use household oil.

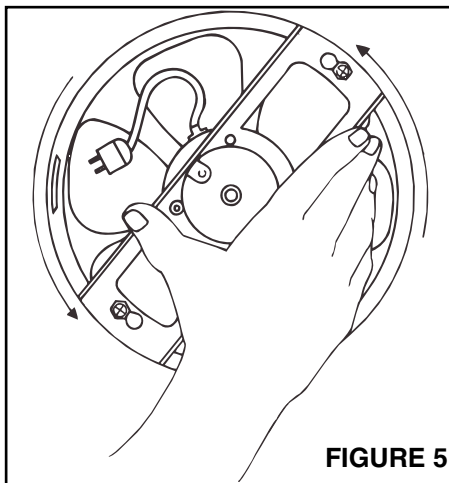

FIGURE 5

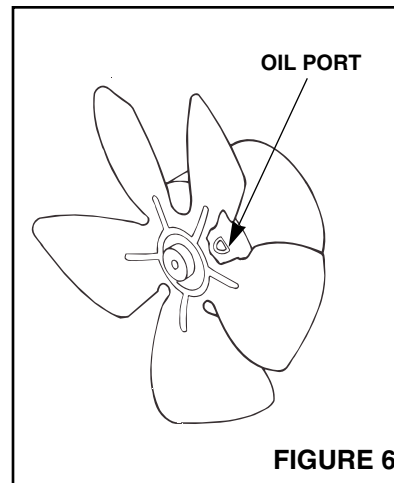

FIGURE 6

NuTone®

One Year Limited Warranty

WARRANTY OWNER: NuTone warrants to the original consumer purchaser of its products that such products will be free from defects in materials or workmanship for a period of one (1) year from the date of original purchase. **THERE ARE NO OTHER WARRANTIES, EXPRESS OR IMPLIED, INCLUDING, BUT NOT LIMITED TO, IMPLIED WARRANTIES OF MERCHANTABILITY OR FITNESS FOR A PARTICULAR PURPOSE.**

During this one year period, NuTone will, at its option, repair or replace, without charge, any product or part which is found to be defective under normal use and service. **THIS WARRANTY DOES NOT EXTEND TO FLUORESCENT LAMP STARTERS OR TUBES, FILTERS, DUCT, ROOF CAPS, WALL CAPS AND OTHER ACCESSORIES FOR DUCTING.** This warranty does not cover (a) normal maintenance and service or (b) any products or parts which have been subject to misuse, negligence, accident, improper maintenance or repair (other than by NuTone), faulty installation or installation contrary to recommended installation instructions.

The duration of any implied warranty is limited to the one year period as specified for the express warranty. Some states do not allow limitation on how long an implied warranty lasts, so the above limitation may not apply to you.

NUTONE'S OBLIGATION TO REPAIR OR REPLACE, AT NUTONE'S OPTION, SHALL BE THE PURCHASER'S SOLE AND EXCLUSIVE REMEDY UNDER THIS WARRANTY. NUTONE SHALL NOT BE LIABLE FOR INCIDENTAL, CONSEQUENTIAL OR SPECIAL DAMAGES ARISING OUT OF OR IN CONNECTION WITH PRODUCT USE OR PERFORMANCE. Some states do not allow the exclusion or limitation of incidental or consequential damages, so the above limitation or exclusion may not apply to you. This warranty gives you specific legal rights, and you may also have other rights, which vary from state to state. This warranty supersedes all prior warranties.

WARRANTY SERVICE: To qualify for warranty service, you must (a) notify NuTone at the address stated below or telephone 1/800-543-8687, (b) give the model number and part identification and (c) describe the nature of any defect in the product or part. At the time of requesting warranty service, you must present evidence of the original purchase date.

Date of Installation

Builder or Installer

Model No. and Product Description

IF YOU NEED ASSISTANCE OR SERVICE:

For the location of your nearest NuTone Independent Authorized Service Center:

Residents of the contiguous United States Dial Free 1-800-543-8687

Please be prepared to provide:

Product model number • Date and Proof of purchase • The nature of the difficulty

Residents of Alaska or Hawaii should write to: NuTone Inc. Attn: Department of National Field Service, 4820 Red Bank Road, Cincinnati Ohio 45227-1599.

Residents of Canada should write to: Broan-NuTone Canada, 1140 Tristar Drive, Mississauga, Ontario, Canada L5T 1H9.

Rev. 03/2001