

## Heat-A-Lite®

MODEL: 9013NL

**IMPORTANT:** Do not mount over tub or in shower stall enclosure.

The NuTone Heat-A-Lite and Night Light consists of the rough-in housing (including the junction box and adjustable hanger bar); a one-piece heater and light assembly, grille and a NuTone wall switch assembly.

### MOUNTING THE HOUSING

#### “A” UNIT

Refer to Figure 1.

1. Nail mounting brackets to the ceiling joists (16" center to center).
2. Insert the adjustable hanger bar in third mounting bracket and nail to joists.

**WARNING:** Do not wedge the housing in any way to throw it out of round.

**NOTE:** For 24" center to center joists, use two (2) adjustable hanger bars (included).

### ADJUSTING THE HOUSING

Refer to Figure 1.

The screws inside the housing may be loosened slightly to allow for adjustment to the finished plaster or ceiling line.

### WIRING

**WARNING:** Be sure heater and switch are properly grounded and all wiring complies with local electrical code.

1. Install double-gang switch box in chosen location.
2. Refer to Figure 2. Run wiring and make connections as illustrated.
3. Use the supplied screws to secure switch bracket assembly to switch box.
4. Use the supplied screws to secure wall plate to switch bracket.

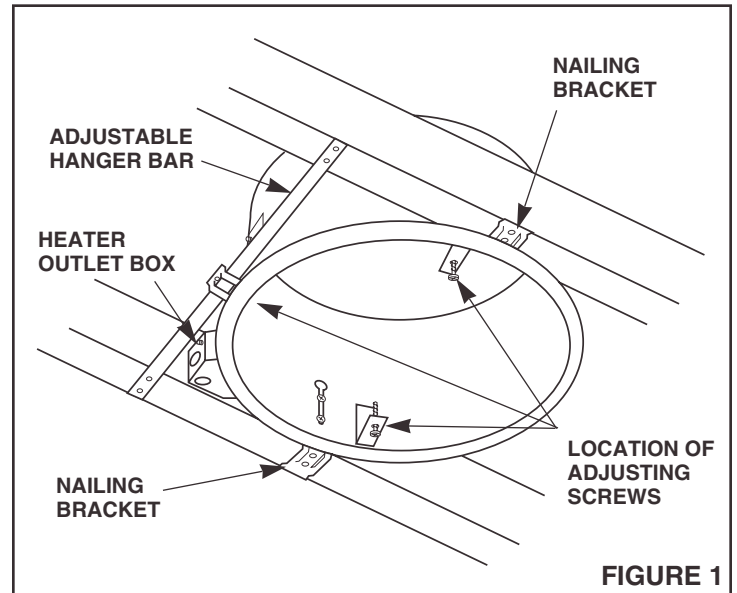

FIGURE 1

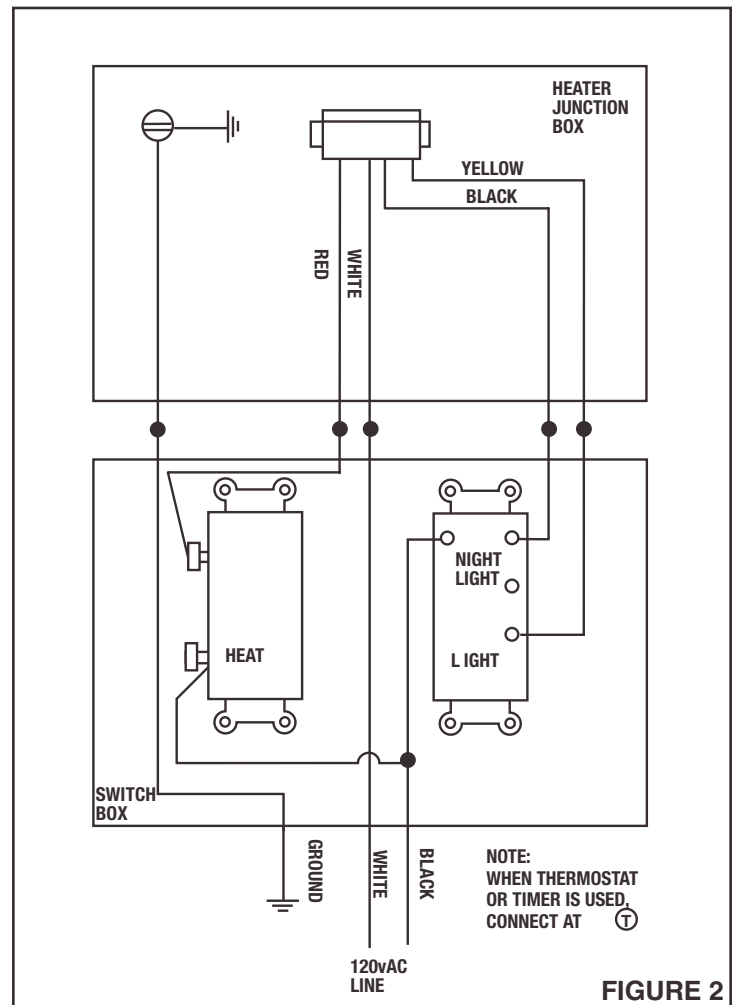

FIGURE 2

## MOUNTING THE "B" UNIT

Refer to Figure 3.

The "B" unit (heater and light assembly) is completely assembled at the factory and ready for installation with the exception of the grille.

1. Insert the hooked hinge of the "B" unit into the slotted hanger bracket of the "A" housing.
2. Insert plug on "B" unit into receptacle in junction box cover.
3. Swing the assembly into place and secure to the "A" unit with the screws provided in the bracket of the "A" unit.
4. Refer to Figure 4. Install the bulbs. **NOTE: 100 watt (maximum) and 7 watt (maximum) for night light.**

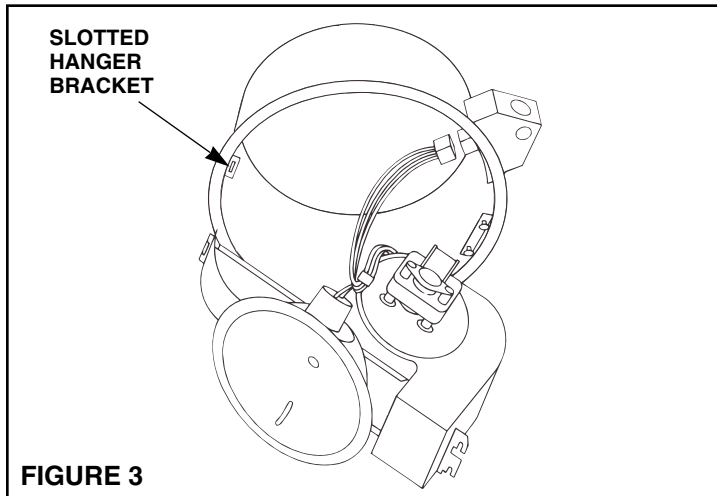

## MOUNTING THE GRILLE

Refer to Figure 4.

Align keyhole slots in the grille with the screws in the brackets on the "A" unit and fasten into place.

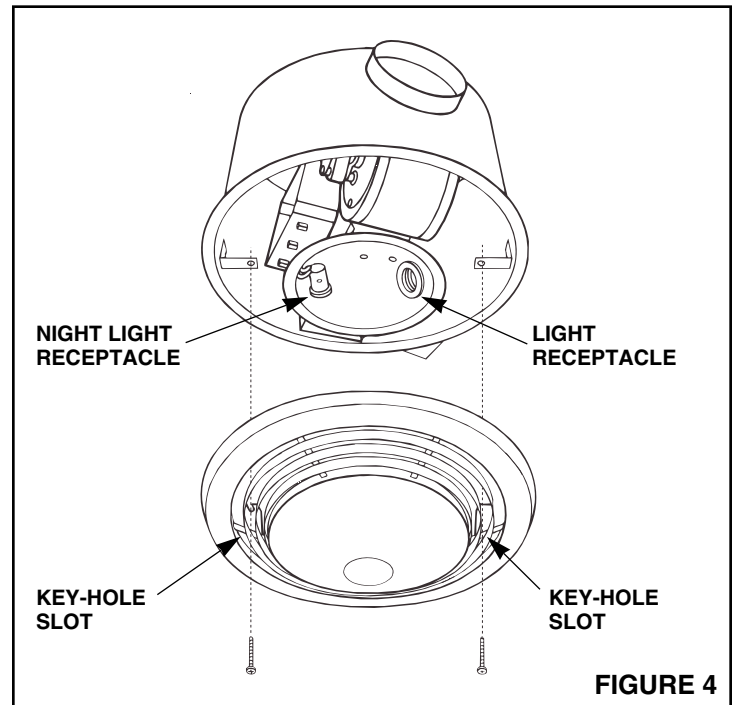

# NuTone®

## One Year Limited Warranty

**WARRANTY OWNER:** NuTone warrants to the original consumer purchaser of its products that such products will be free from defects in materials or workmanship for a period of one (1) year from the date of original purchase. **THERE ARE NO OTHER WARRANTIES, EXPRESS OR IMPLIED, INCLUDING, BUT NOT LIMITED TO, IMPLIED WARRANTIES OF MERCHANTABILITY OR FITNESS FOR A PARTICULAR PURPOSE.**

**During this one year period,** NuTone will, at its option, repair or replace, without charge, any product or part which is found to be defective under normal use and service. **THIS WARRANTY DOES NOT EXTEND TO FLUORESCENT LAMP STARTERS OR TUBES, FILTERS, DUCT, ROOF CAPS, WALL CAPS AND OTHER ACCESSORIES FOR DUCTING.** This warranty does not cover (a) normal maintenance and service or (b) any products or parts which have been subject to misuse, negligence, accident, improper maintenance or repair (other than by NuTone), faulty installation or installation contrary to recommended installation instructions.

The duration of any implied warranty is limited to the one year period as specified for the express warranty. Some states do not allow limitation on how long an implied warranty lasts, so the above limitation may not apply to you.

**NUTONE'S OBLIGATION TO REPAIR OR REPLACE, AT NUTONE'S OPTION, SHALL BE THE PURCHASER'S SOLE AND EXCLUSIVE REMEDY UNDER THIS WARRANTY. NUTONE SHALL NOT BE LIABLE FOR INCIDENTAL, CONSEQUENTIAL OR SPECIAL DAMAGES ARISING OUT OF OR IN CONNECTION WITH PRODUCT USE OR PERFORMANCE.** Some states do not allow the exclusion or limitation of incidental or consequential damages, so the above limitation or exclusion may not apply to you. This warranty gives you specific legal rights, and you may also have other rights, which vary from state to state. This warranty supersedes all prior warranties.

**WARRANTY SERVICE:** To qualify for warranty service, you must (a) notify NuTone at the address stated below or telephone 1/800-543-8687, (b) give the model number and part identification and (c) describe the nature of any defect in the product or part. At the time of requesting warranty service, you must present evidence of the original purchase date.

Date of Installation

Builder or Installer

Model No. and Product Description

### IF YOU NEED ASSISTANCE OR SERVICE:

For the location of your nearest NuTone Independent Authorized Service Center:

**Residents of the contiguous United States** Dial Free 1-800-543-8687

Please be prepared to provide:

Product model number • Date and Proof of purchase • The nature of the difficulty

**Residents of Alaska or Hawaii should write to:** NuTone Inc. Attn: Department of National Field Service, 4820 Red Bank Road, Cincinnati Ohio 45227-1599.

**Residents of Canada should write to:** Broan-NuTone Canada, 1140 Tristar Drive, Mississauga, Ontario, Canada L5T 1H9.

Rev. 03/2001