

Built-In Central Cleaning System

MODEL: CV350, CV353, CV450, CV553

SYSTEM PLANNING AND LAYOUT	2
Examples	2
Locating the Power Unit	3
Tubing and Wall Inlet Location	3
Locating Access Keys in Existing Construction	3
INSTALLATION IN NEW CONSTRUCTION	4-8
Wall Inlet Rough-In	4
Installing the Tubing	5
Wall Inlet Installation	
Model 360 Wall Inlets	6
Model 330 Wall Inlet	6
Model CI390 Wall Inlet (Electrified Inlet)	7
POWER UNIT INSTALLATION	8
Dimensional Chart	8
Mounting	8
Tubing Connections at Power Unit	8
Wiring	8
INSTALLATION IN EXISTING CONSTRUCTION	9-10
Wall Inlet Installation	
Model 360 Wall Inlets	9
Model 330 Wall Inlet	10
FLOOR INLET INSTALLATION	10-11
FINAL SYSTEM CHECK	11
WARRANTY	12



MODEL CV450 SHOWN

SYSTEM PLANNING AND LAYOUT

The NuTone Central Cleaning System consists of a Power Unit, PVC Tubing and Fittings, Wall Inlets, a flexible Hose and various cleaning Attachments.

The Power Unit is designed to be wall-mounted away from the living area of the home and connected to the living area by means of permanently installed in-wall tubing, fittings and inlets.

Generally, an installation will require 3 to 4 inlets and 16 to 20 feet of tubing per inlet. It is suggested that a floor plan be used to more accurately determine the quantity of materials needed.

As an aid in planning the installation in either new or existing construction, look at the following examples. You should be able to adapt the examples shown to your specific home layout.

THE RANCH STYLE HOUSE

Here the power unit is mounted in the garage. The intake and exhaust tubing, the only exposed tubing in the installation, runs up the garage wall and into the attic. The trunk line runs horizontally through the attic from the power unit to the farthest inlet location. Branch lines spread throughout the attic, connecting the trunk line to the inlet tubing. Each inlet tube is threaded vertically through an inside wall.

Located in hallways, and in large rooms, the inlets are placed to provide maximum access to all cleaning areas. See Figure 1.

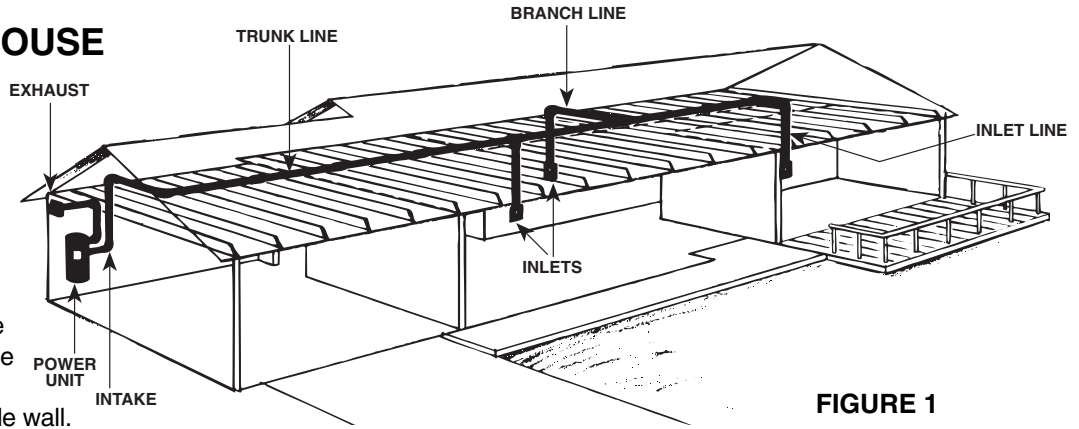

FIGURE 1

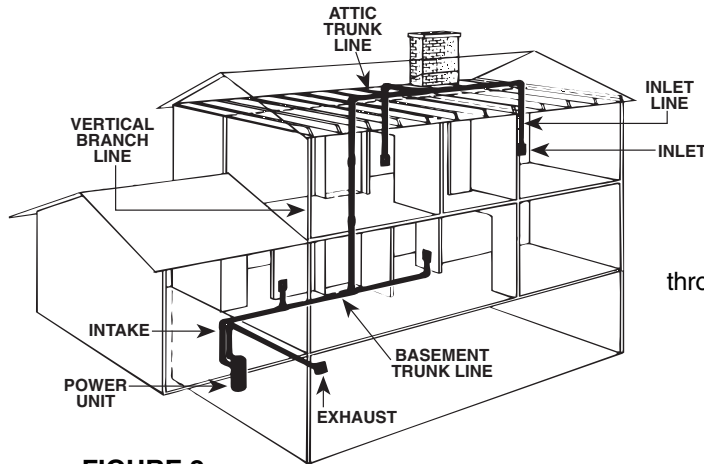

FIGURE 2

THE TWO-STORY HOUSE

A double-trunk line system is commonly used in two-story houses.

In the installation shown at left, the power unit is mounted in the basement. The intake tubing runs up the basement wall and connects to the main trunk line, which runs along the unfinished basement ceiling. Two first-floor inlets are connected to the basement trunk line by vertical inlet lines run through interior walls. In the center of the house, a vertical branch line runs from the basement trunk line, through stacked closets, up into the attic. A second trunk line runs across the attic and two branch lines connect to inlet lines which are dropped down through upstairs interior walls. See Figure 2.

THE SPLIT-LEVEL HOUSE

Like the two-story house, the split level installation commonly calls for a two-level trunk line. Here, the power unit is located in the garage.

The intake tubing runs exposed up the garage wall and into the ground level section's attic. Two branch lines connect this part of the trunk line to inlet lines which are dropped inside interior walls.

A vertical branch line runs to the upstairs attic, where the trunk line branches into a T-shape. This trunk line connects to two upstairs inlet lines and to one inlet line which drops through an upstairs wall and down into the third-level utility room to service this entire level. See Figure 3.

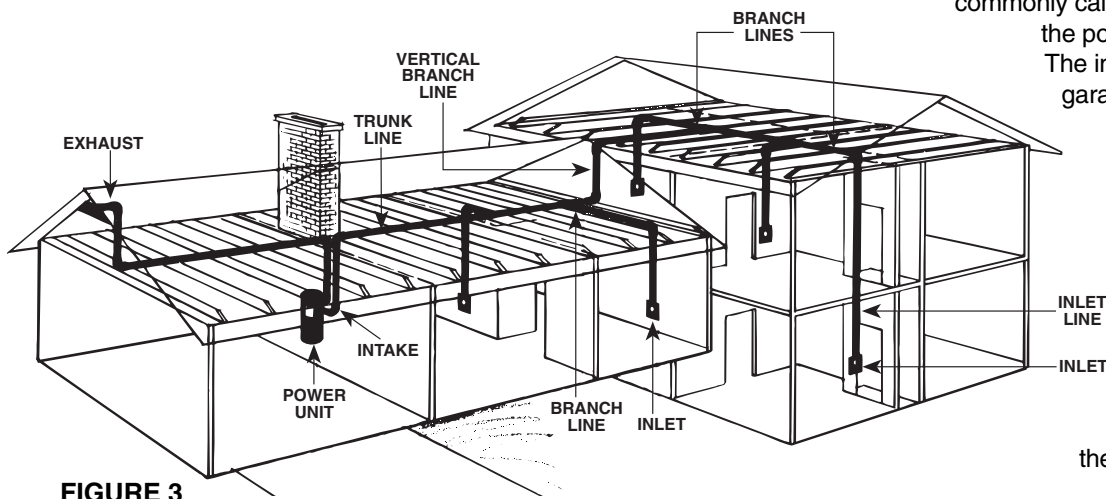

FIGURE 3

LOCATING THE POWER UNIT

- Locate the power unit away from the general living area in an accessible location for changing the soil bag and periodically cleaning the secondary filter.
- When planning, remember the power unit is equipped with an inlet to service a garage, basement, utility room, etc., wherever it is located.
- Locate the power unit within six feet of a grounded electrical outlet. The power unit requires a 120vAC power source.
- Do not locate the power unit close to a source of extreme heat (i.e., water heater) or in an area with a high ambient temperature (i.e., attic, furnace room).
- If the power unit is located in a closet or a small utility room, make sure the area is well-ventilated (i.e., with door louvers).
- Exhausting the power unit to the outside is recommended for optimal performance but is not required. The exhaust should not be vented into a wall, a ceiling or a concealed space in the house. If the exhaust line is vented outside the home, Model 393 Wall Cap or a roof vent are recommended.

WARNING: Power unit must not be mounted in a high ambient temperature area such as attic, furnace room, etc.

TUBING AND WALL INLET LOCATIONS

1. Locate inlets on interior walls, choosing central locations which allow several rooms to be cleaned from a single inlet using a 30 foot long hose.
2. The tubing installation should consist of a main trunk line running from the farthest wall inlet to the power unit location, with branch lines running to each additional inlet. Keep all tubing lines as straight as possible and use as few fittings as possible. Beginning at the area farthest from the power unit, choose a tentative inlet location. Measure 30 feet from the proposed inlet location to the farthest corner of the rooms to be cleaned by that inlet to determine if inlet location is proper.
3. If working from blueprints (or building plans drawn at $\frac{1}{4}'' = 1 \text{ ft.}$ scale), use a $7\frac{1}{2}''$ chain as your guide to determine inlet locations.
4. Move tentative inlet location if necessary. Use the same procedure to determine each additional inlet location, always working toward the power unit.
5. Be sure tubing will not interfere with electrical, plumbing or other mechanical installations.
6. Locate inlets within six feet of an electrical receptacle to allow use of optional current-carrying hose.
7. Be sure inlets will not be blocked by doors or furniture.

LOCATING ACCESS KEYS IN EXISTING CONSTRUCTION

Let's say, for example, you have a two-story house and you want to locate the power unit in the basement. If you can't find interior walls on both the first and second floors which line up and are free from obstacles. How do you get from the basement to the attic?

Unless your home is a ranch-style house where a single trunk line can run directly through the attic or basement, you should first investigate your house to find the key to running your tubing from level to level. Look for an accessible area free from obstructions that will accommodate the 2" tubing.

If you understand how your existing home is constructed, it can be relatively easy to find access routes to run the tubing. Refer again to the illustration on page 2 as you consider your home construction.

Some of the keys you might find in your home are illustrated here.

Stacked Closets or Laundry Chute.

Many homes will have an upstairs closet located directly above a downstairs closet. It is easy to run the tubing from one floor level to another inside these stacked closets. In these installations the tubing is often left exposed inside the closets. See Figure 4. A laundry chute could also provide access from basement to upper floors.

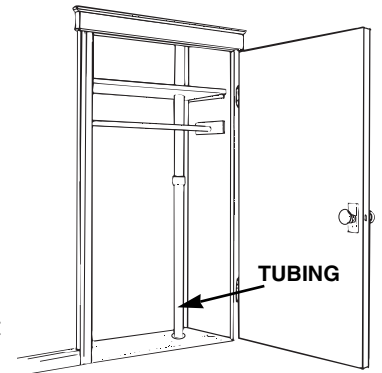

FIGURE 4

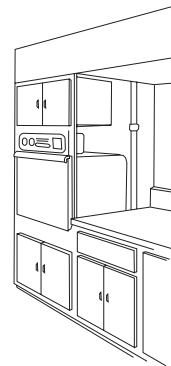

FIGURE 5

Built-In Appliances. You will often find a hollow space behind built-in kitchen appliances. If this space lines up with an obstruction-free interior wall above or a closet, this might be a key to your installation. See Figure 5. You may also want to consider running exposed tubing through cabinets or cupboards.

Cold-Air Return. A cold-air return often provides a straight run from basement to other levels of the house. See Figure 6. The ductwork is easily cut for access. Seal around the tube when completing the installation.

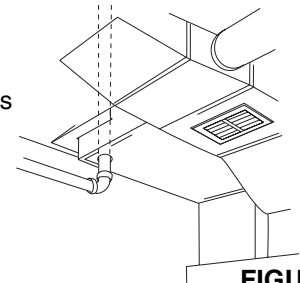

FIGURE 6

INSTALLATION IN NEW CONSTRUCTION

WALL INLET ROUGH-IN

Once the locations for wall inlets have been determined, mount all inlet brackets.

1. Choose the appropriate mounting bracket for the inlet being installed. (See chart.)

NuTone Inlet	Rough-in
330 Series	329
360 Series	361
CI390 Series Electrified Inlet	CI390RK

2. To locate bracket on wall stud, measure approximately 18" up from finished floor level. (Height may vary according to individual preference.)

MODEL 361 (FOR USE WITH 360 INLETS)

3. Refer to Figure 7. Nail bracket to side of stud so that front edge of bracket is flush to front of stud. (The bracket may also be nailed to the front edge of the stud. See face mounting illustrated. For face mounting, use locating tabs on bracket for proper alignment.)
4. Refer to Figure 8. Remove cardboard from plaster guard frame. Using four (4) provided screws, attach the appropriate flanged fitting and inlet seal to back of inlet.
5. Replace cardboard in plaster guard frame.

MODEL 329 (FOR USE WITH 330 INLETS)

6. When using Model 329, glue elbow to mounting plate. Attach to stud as shown in Figure 9.

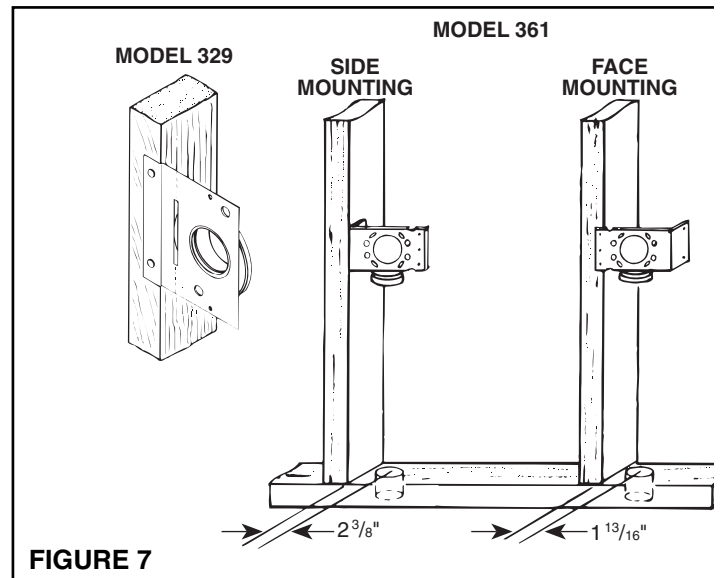

FIGURE 7

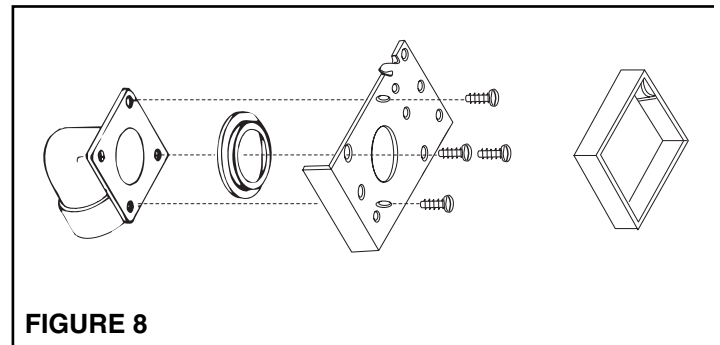

FIGURE 8

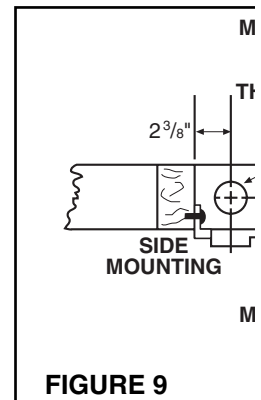

FIGURE 9

INSTALLATION IN NEW CONSTRUCTION (continued)

INSTALLING THE TUBING

Use the following installation guidelines when installing tubing.

1. Start tubing installation at farthest inlet and work toward the power unit.
2. Tubing run to the power unit should be as straight as possible.
3. When assembling sections with elbows and tees, make sure the curve in the fitting is aligned so that the air flows toward the power unit.
4. Branch lines should always join the trunk line from above or from the same level. Never join a branch line from an angle below the trunk line.
5. Refer to Figure 28 on page 8. Run low voltage wiring (Model 376-UL) and secure wiring to tubing as tubing is installed. Model CF-380 Pipe Support can be used to support long runs of tubing (position near joists) and to clip wire along tubing. Secure tubing to joists or studs. Leave approximately 6" of wire for connection to each inlet.
6. Cut a 2½" diameter hole in sole plate, header or stud directly in line with opening of inlet bracket fitting.
Note Figure 6 for center line dimensions.
7. Refer to Figure 11. Measure length of tubing needed to connect inlet to trunk line. Allow approximately ¾" of tubing for inserting into fittings.
8. Refer to Figure 12. Cut tubing, keeping cut square.
9. Refer to Figure 13. Remove burrs from both inside and outside of tubing.
10. Before cementing, pre-assemble section to inlet fitting, check for proper length.
11. Refer to Figure 14. Apply PVC cement (Model 379) to outside of tubing. Coat tubing approximately 1" back. Take care to keep cement from inside of tube.
12. Refer to Figure 15. Insert tubing into fitting with a twisting motion to evenly spread cement. Be sure tubing is firmly seated in fitting.
13. If fittings have been attached to tubing at the end opposite the inlet bracket, be sure alignment is proper before cement sets.
14. Refer to Figure 16. Tape wire to tubing to hold in place and insert through hole in inlet bracket.
15. Connect each inlet line and branch line into main trunk line. Complete low voltage wiring as main trunk line is continued back to power unit.

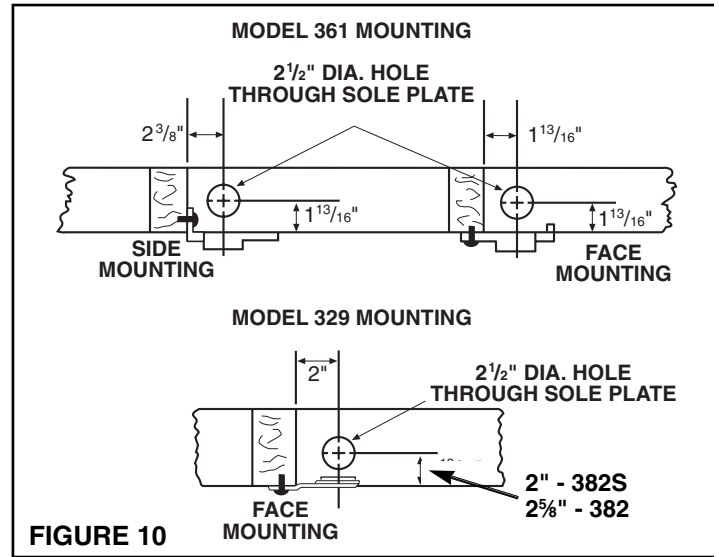

FIGURE 10

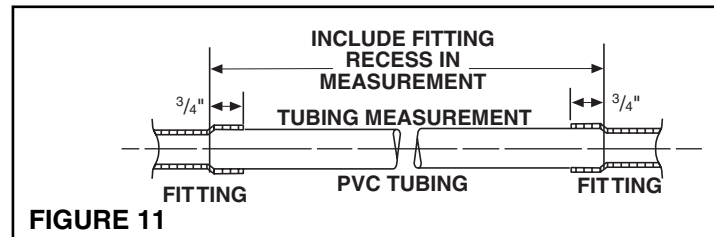

FIGURE 11

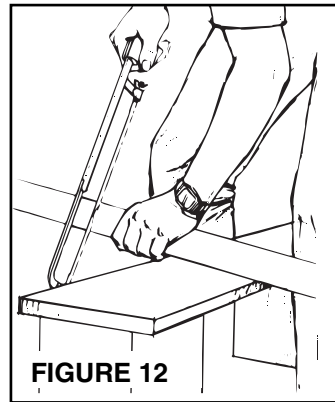

FIGURE 12

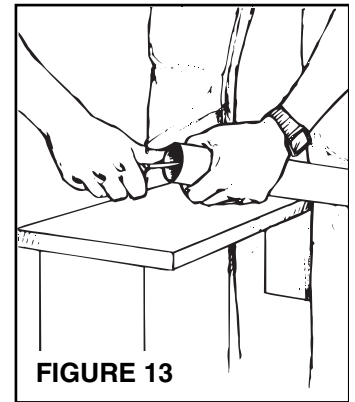

FIGURE 13

Caution: When tubing is run through the wall stud, sole plate, headers - or anywhere that building materials will be attached - place a nail plate (Model 378) over that area (on both sides if necessary) to prevent nails from piercing tubing.

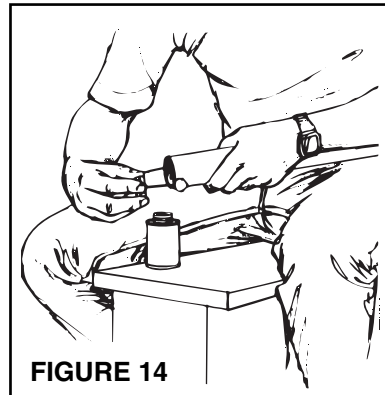

FIGURE 14

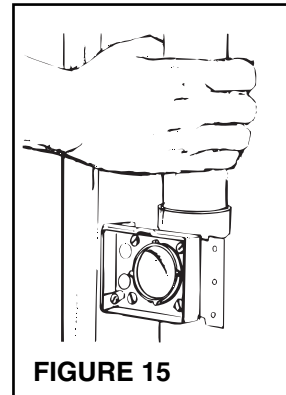

FIGURE 15

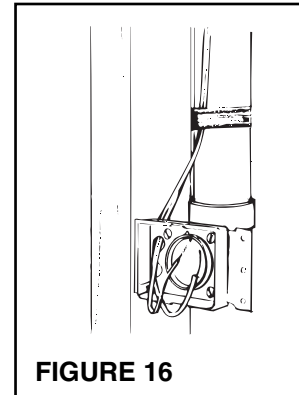

FIGURE 16

INSTALLATION IN NEW CONSTRUCTION (continued)

WALL INLET INSTALLATION

MODEL 360 WALL INLET (361 Rough-In)

1. Remove the cardboard plaster guard.
2. Refer to Figure 17. For some drywall or panel construction, the plaster frame will extend beyond the finished wall. In this case, remove plaster frame from mounting bracket by removing mounting screws.

NOTE: When using the Model 361 inlet bracket on walls thinner than $\frac{1}{2}$ " , use a $\frac{1}{4}$ " spacer (not furnished) between the wall and the inlet bracket. See Figure 20. Spacer may be made from plywood, Masonite™, etc. Contact cement may be used to hold spacer in place during assembly. Configuration of spacer may vary depending upon installation.

3. Refer to Figure 18. Connect 2-conductor low voltage wire to terminal screws on back of wall inlet. Cap off both wires using wire nut (supplied).
4. Guide excess wire back through the hole in inlet bracket and flanged fitting
5. Refer to Figure 19. Place inlet into mounting bracket and secure.

NOTE: when wall inlets are installed in walls that are less than $\frac{1}{2}$ " thick or when inlets are installed back-to-back in a wall, the tube of the wall inlet may extend into elbow area of the flanged fitting and cause blockage. Shorten the wall inlet tube to prevent this condition. Refer to Figure 21.

For extra thick walls, use Model 399 Extension Sleeve to connect inlet to the flanged fitting.

MODEL 330 WALL INLET (329 Rough-in)

See Figure 23.

1. Connect 2-conductor low voltage wire to terminal screws on back of wall inlet.
2. Align inlet mounting holes with holes in mounting plate.
3. Place inlet into mounting plate and secure with two provided screws.

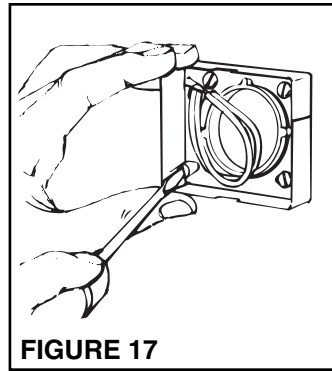

FIGURE 17

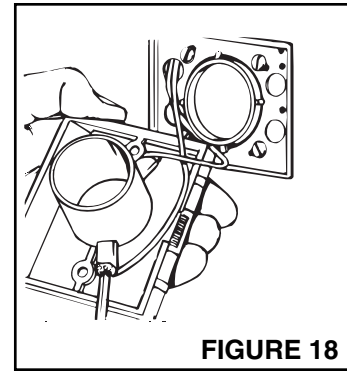

FIGURE 18

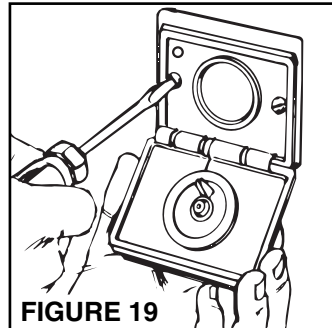

FIGURE 19

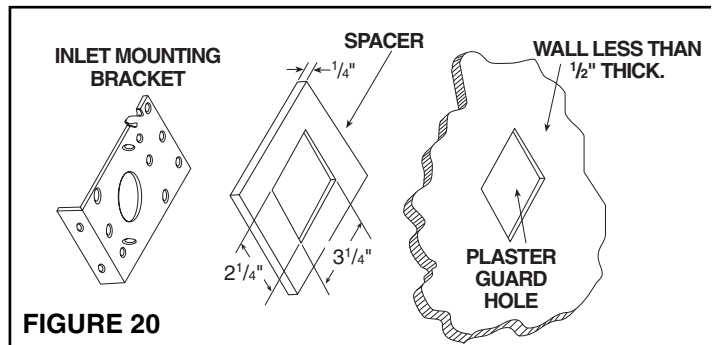

FIGURE 20

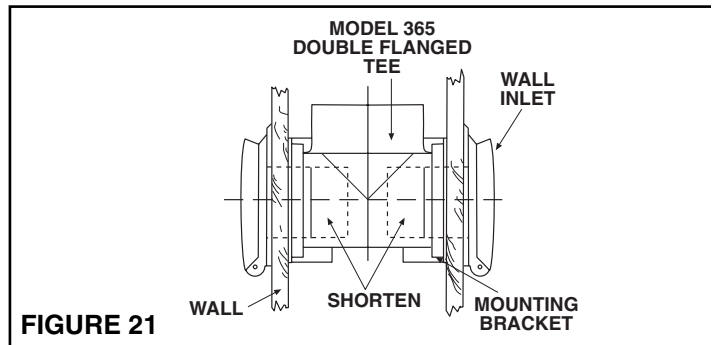

FIGURE 21

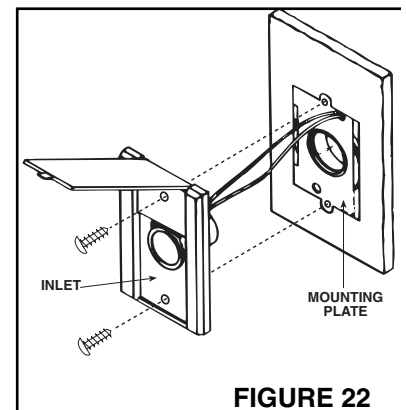

FIGURE 22

INSTALLATION IN NEW CONSTRUCTION (continued)

CI-390 ELECTRAVALVE™ ELECTRIFIED INLET INSTALLATION (CI-390RK Rough-In) (Not available in Canada)

1. See Figure 23. Fasten the mounting plate to a stud within three studs (48") of an electrical outlet box. Measure and mark the wire 10" from the plug (A). Feed the wire through the top hole in the mounting plate (just above the circular opening). Snap the molded plug into the mounting plate as pictured (B). This will keep it secure and out of harm's way during drywalling and finishing. Line up the wire at the previously measured 10" mark with the strain relief channel on the back of the mounting plate. Secure it in place with the supplied wire tie (C).
2. Run the inlet wire to the adjacent electric box. If you must run wire through a stud, drill directly through the center of the stud (D).
3. See Figure 24. Place the exposed ends of the two wires into the electrical box through a strain relief channel (E). Tighten the strain relief channel (do not overtighten) on the white sheathing leaving 1/2" of this sheathing exposed inside of the outlet box.

Fold the 6" of black and white wire into the outlet box. Leave the wires to be connected by the electrician when plug receptacles are being installed. (Attention: Power tools such as routers are not recommended for use with the inlet installation, as removal of drywall with these devices may cause damage to the mounting plate and/or inlet plug).

4. Once drywall and finishing processes have been completed, remove molded plug from mounting plate (with the aid of a slot screwdriver) and snap it into the wing slot at the back of the inlet (F). (Please note: molded plug fits one way only, with the narrow opening at the top). Insert inlet into the mounting plate and secure inlet to mounting plate with screws provided.

NOTE: All electrical devices such as the electrified inlet should be reported to the construction electrician for listing on the inspection report for building inspection purposes.

NOTE: Plumb inlet to tubing using NuTone Model 382-S 90° EII fitting.

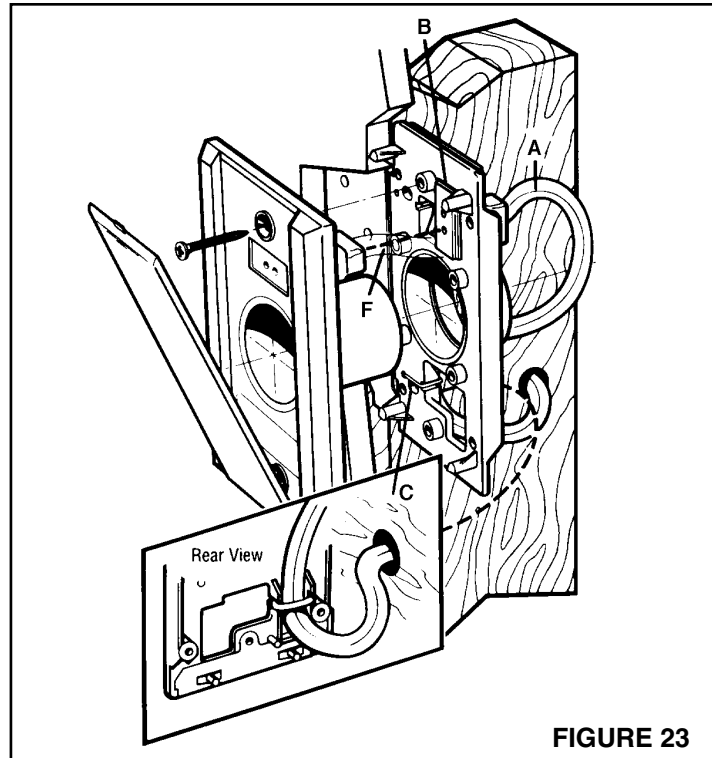

FIGURE 23

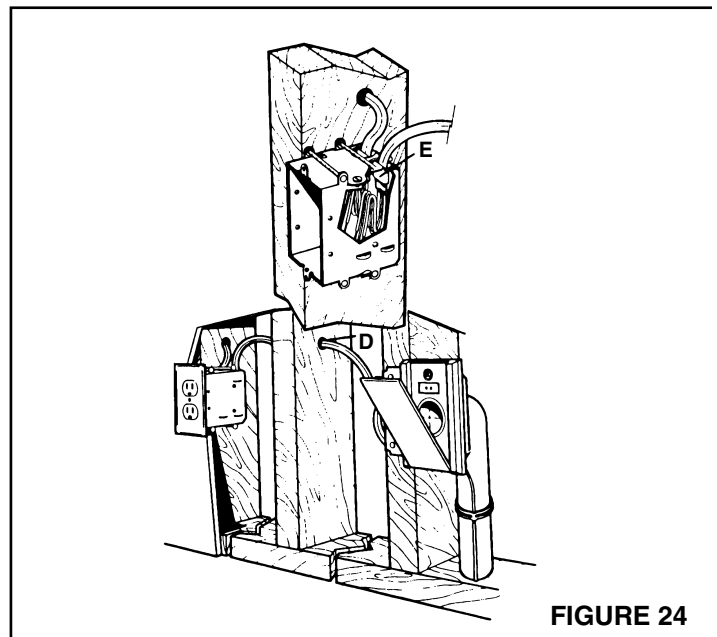
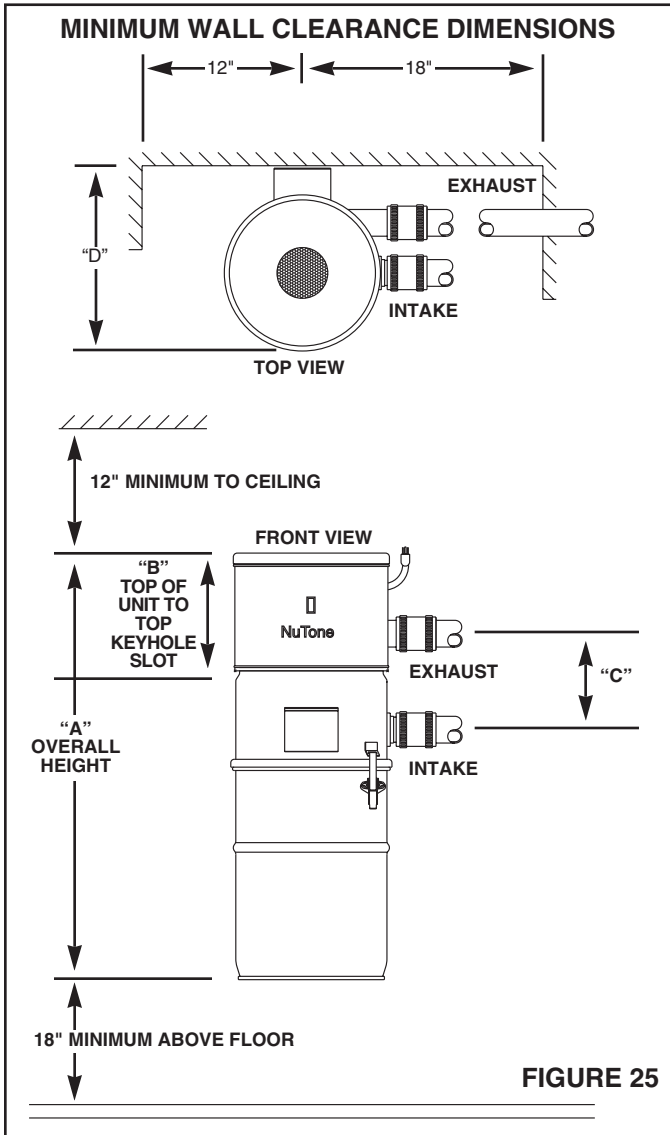

FIGURE 24

POWER UNIT INSTALLATION



DIMENSIONAL CHART

MODELS				
DIMENSION	CV350	CV353	CV450	CV553
A	30½"	32¼"	36¼"	32¼"
B	5⅝"	7¾"	10½"	7¾"
C	6"	6⅞"	12"	6⅞"
D	13⅝"	13⅝"	15¾"	13⅝"
E	6⅞"	6⅞"	6½"	6⅞"

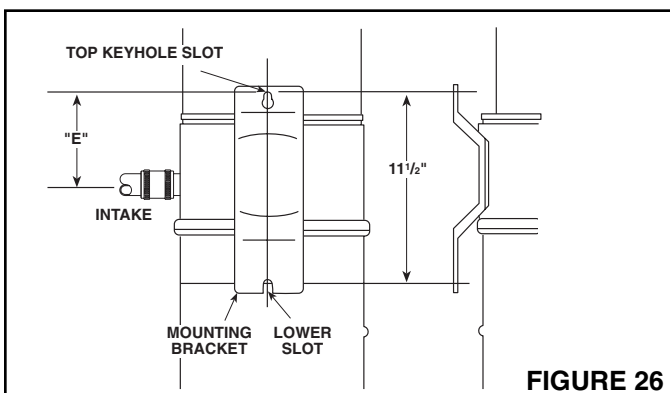

MOUNTING See Figure 25. Also refer to page 3.

1. Locate power unit within six feet of a grounded electrical outlet.
2. Drill ⅜" diameter pilot holes for the two (2) mounting screws in a wall stud or strong support. See Figure 26.
3. Tighten mounting screws. Leave approximately ⅛" to ⅜" clearance between head of screw and wall.
4. Hang power unit onto mounting screws. Make sure top keyhole slot and lower slot in mounting bracket are engaged behind mounting screws. Pull down to secure.
5. Remove lower canister from power unit. Make sure bag is properly installed in power unit. Remove extra bag and homeowner's manual. Securely replace canister.

TUBING CONNECTIONS AT POWER UNIT

1. Using rubber couplings and hose clamps to connect intake and exhaust tubing.
2. Connect intake tubing to intake tube on power unit.
3. Connect mufflers and exhaust tubing to upper exhaust tubes on the power unit.
4. Make sure all tubing connections are air tight.
5. The exhaust should not be vented into a wall, ceiling or concealed space in the house. Exterior vented exhaust lines should be terminated using Model 393 Wall Caps or appropriate louvered exhaust vents.

WIRING See Figure 27.

Grounding Instructions – This appliance must be grounded. If it should malfunction or break down, grounding provides a path of least resistance for electric current, to reduce the risk of electric shock. This appliance is equipped with a cord having an equipment-grounding conductor and grounding plug. The plug must be plugged into an appropriate outlet that is properly installed and grounded in accordance with all local codes and ordinances.

Danger – *Improper connection of the equipment-grounding conductor can result in a risk of electric shock.* Check with a qualified electrician or service person if you are in doubt as to whether the outlet is properly grounded. Do not modify the plug provided with the appliance – if it will not fit the outlet, have a proper outlet installed by a qualified electrician.

This appliance is for use on a nominal 120 volt circuit and has a grounding plug. Make sure that the appliance is connected to an outlet having the same configuration as the plug. No adapter should be used with this appliance.

1. Connect low voltage wire (18 gauge, 2-conductor, Model 376) to crimp connectors located on outside of the power unit.
2. The power unit is equipped with a six foot grounded cord. Plug cord into 120 volt grounded receptacle.

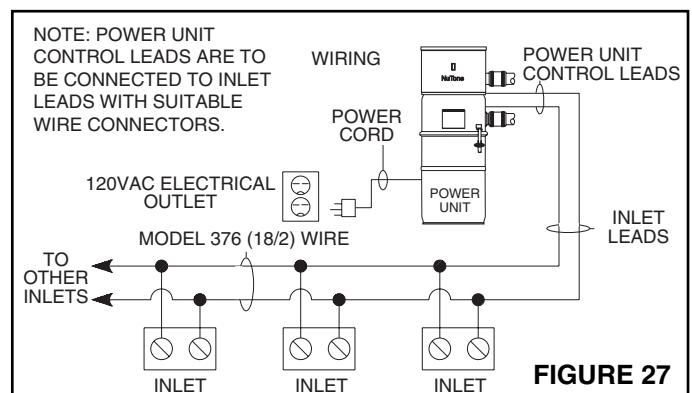

INSTALLATION IN EXISTING CONSTRUCTION

Use the following procedures for installation in existing construction. Starting from farthest wall inlet location, install each inlet as described below. Working back toward power unit, connect each inlet line and branch line into main trunk line. See page 5. Complete low voltage wiring as main trunk line is continued back to power unit. Mount power unit and complete wiring. See page 8.

WALL INLET INSTALLATION

1. See Figure 29. A small 'pilot' or 'locating' hole can be drilled behind baseboard toe strip to determine proper location of 2½" diameter tubing hole in sole plate.
2. Measure the total thickness of the wall, including baseboard. One half of this wall thickness measured from the pilot hole (dimension 'X') will determine the proper location of the 2½" tubing hole in the sole plate.
3. Once desired inlet locations have been determined, cut a 2½" hole in sole plate directly in line with proposed inlet location. Check through tubing hole to be sure no obstruction exists.
4. Be sure tubing hole is centered in sole plate and directly in line with proposed wall inlet cutout.

MODEL 360 SERIES INLETS (361 Rough-In)

NOTE: If 330 Wall Inlet is being used refer to Model 330 Wall Inlet Installation on next page.

5. If area is clear, cut an inlet opening in the wall approximately 18" above the floor. Make sure wall opening and 2½" tube hole line up (Figure 29).
6. Cut a length of tubing that will extend from inlet opening to a point below floor level (or above ceiling level in attic installation). Tape low voltage wire to tube and insert tube through predrilled hole to a level opposite the wall opening.
7. Apply cement to tube and install flanged wall fitting. Make sure fitting is well seated and sealed (Figure 30).
8. Remove plaster frame from mounting bracket. Pull low voltage wire through hole in bracket and insert bracket into cutout. Secure bracket to flanged fitting with four screws provided. Be sure seal is secure between flange fitting and mounting bracket (Figure 31).
9. Attach the low voltage wires to terminal screws on back of wall inlet (Figure 32).
10. Insert wall inlet into bracket and secure with the two screws provided (Figure 33).

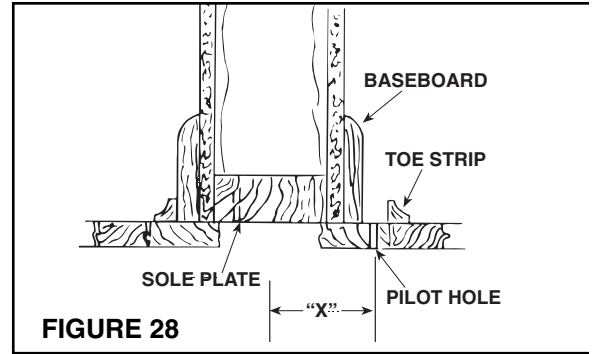

FIGURE 28

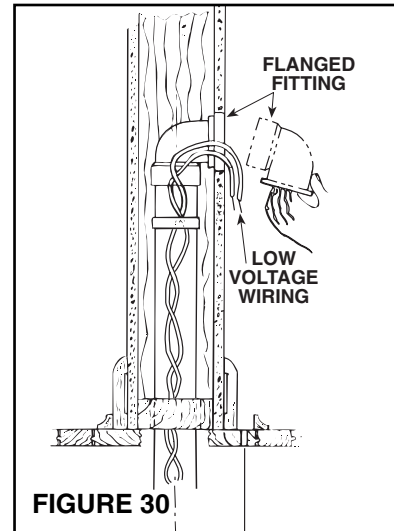

FIGURE 30

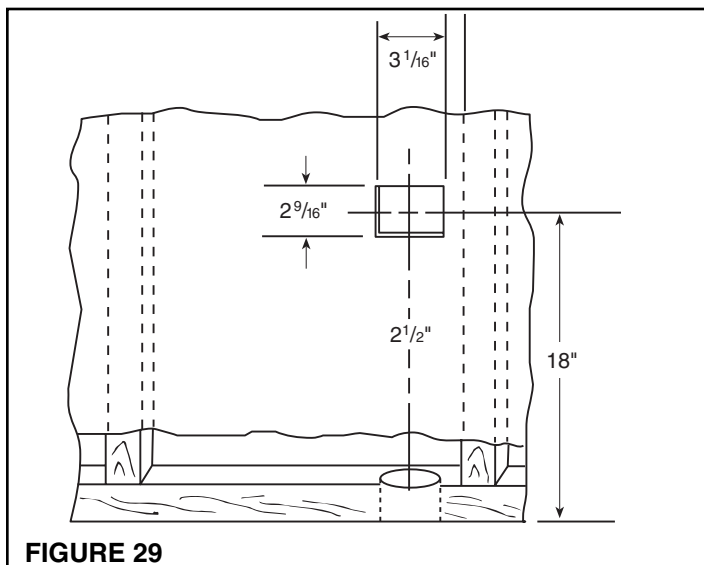

FIGURE 29

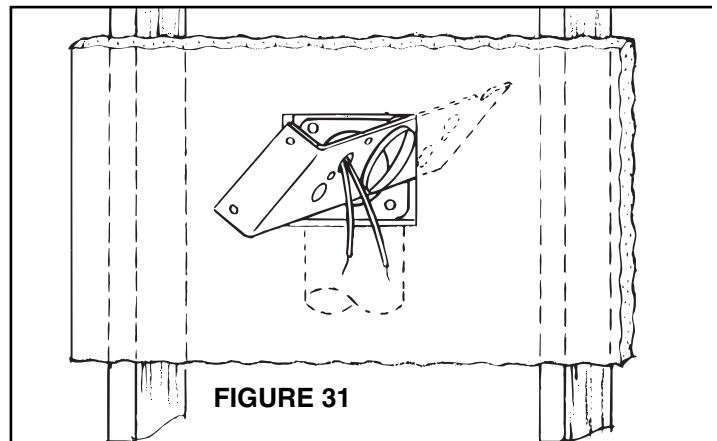

FIGURE 31

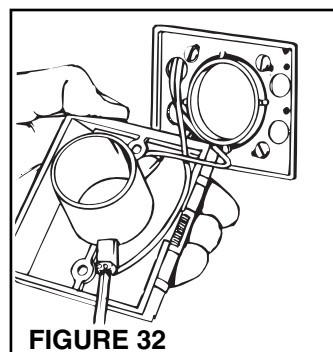

FIGURE 32

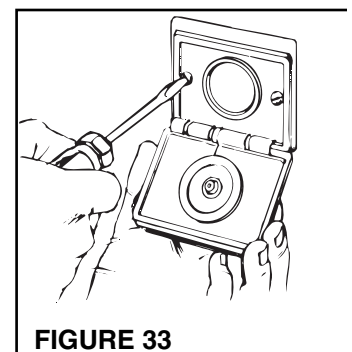

FIGURE 33

NOTE: If the wall for mounting the Model 360 inlet is less than ½", a spacer must be used. See Figure 20 on page 6 as a guide.

INSTALLATION IN EXISTING CONSTRUCTION (continued)

MODEL 330N WALL INLET INSTALLATION (329 Rough-in)

1. Make cutout according to dimensions in Figure 34.
2. Refer to Figure 35. Break off nail plate at scored line.
3. Refer to Figure 36. Glue elbow to mounting plate, place assembly into cutout, and attach elbow to tubing inside the wall.
4. Make sure mounting holes are exactly at top and bottom.
5. Connect 2-conductor low voltage wire to terminal screws on back of wall inlet.
6. Refer to Figure 37. Align inlet mounting holes with mounting plate holes, place inlet into mounting plate, and secure with provided screws. NOTE: If 382-S shorter radius elbow is used, it may be necessary to use the short mounting screw to avoid interference with elbow.

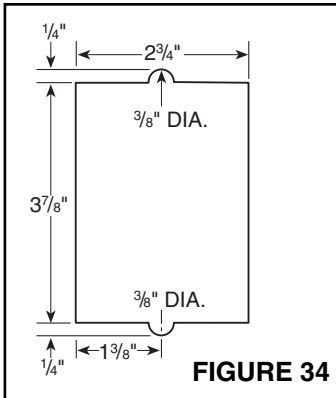

FIGURE 34

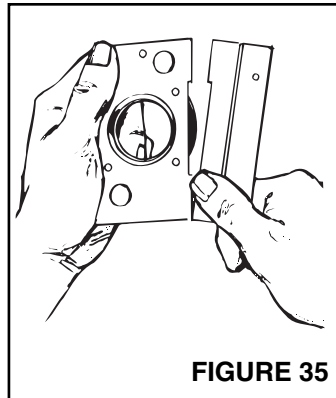

FIGURE 35

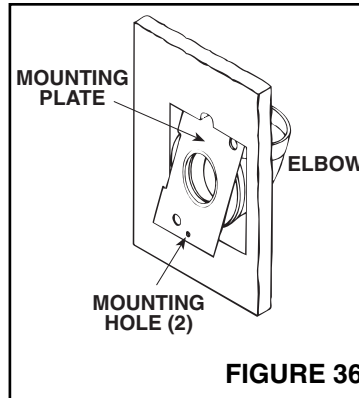

FIGURE 36

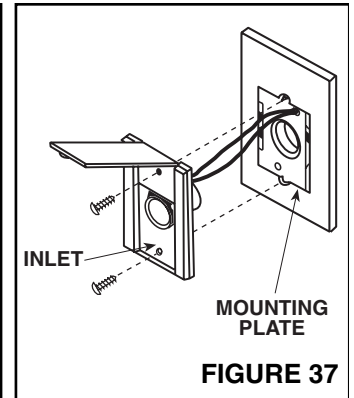

FIGURE 37

FLOOR INLET INSTALLATION IN NEW & EXISTING CONSTRUCTION

MODEL 360 SERIES INLETS (361 Rough-in)

1. Refer to Figures 38 and 39. After floor inlet location has been selected, cut a $3\frac{1}{16}$ " x $2\frac{9}{16}$ " square hole in floor. Center line of inlet must be located at least $2\frac{1}{2}$ " from wall to allow cover to be opened when hose is inserted.
2. Determine direction of tubing and attach appropriate flanged fitting to mounting bracket with four (4) screws supplied. **Be sure mounting bracket flange does not interfere with tubing and seal is securely in place.**
3. Refer to Figure 40. Position bracket with frame and flanged fitting assembly into cutout from below and secure to sub floor.
4. Refer to Figure 41. Large end of Model 399 extension sleeve should be cut to length to allow proper seating of inlet against floor or carpet.
5. Refer to Figure 42. Pull low-voltage 2-conductor wire through mounting bracket and attach to terminal screws on back of floor inlet. Cement extension sleeve to model 360 inlet. Insert extension sleeve through vinyl gasket in mounting bracket and firmly seat into flanged fitting.
6. For convenience of operation, floor inlet should be installed to open back toward wall.
7. Refer to Figure 40. Secure floor inlet in place with two screws.

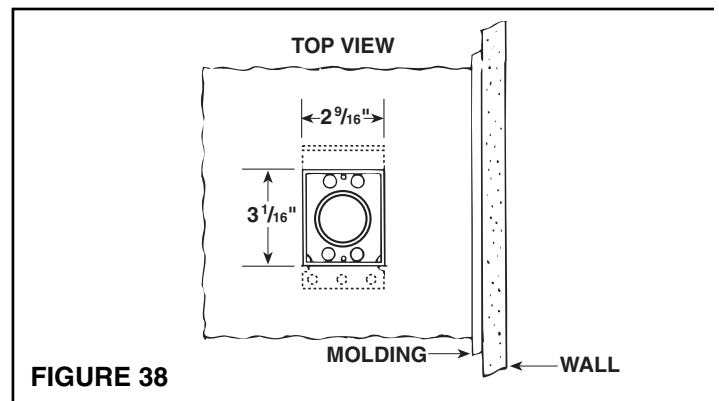

FIGURE 38

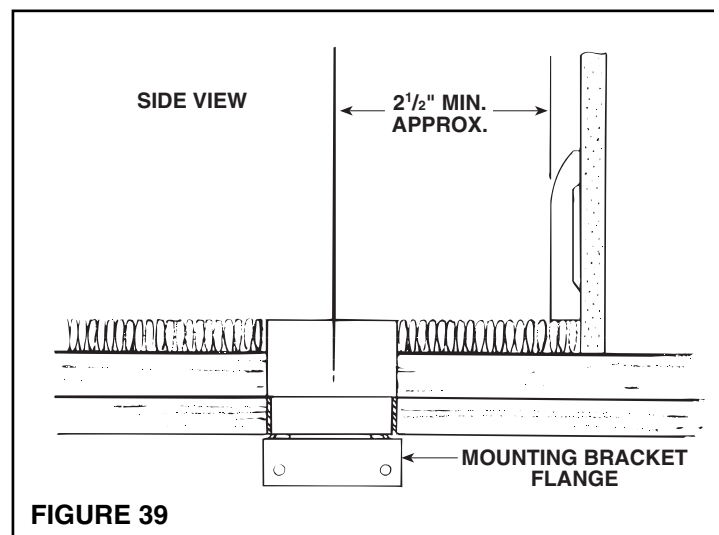
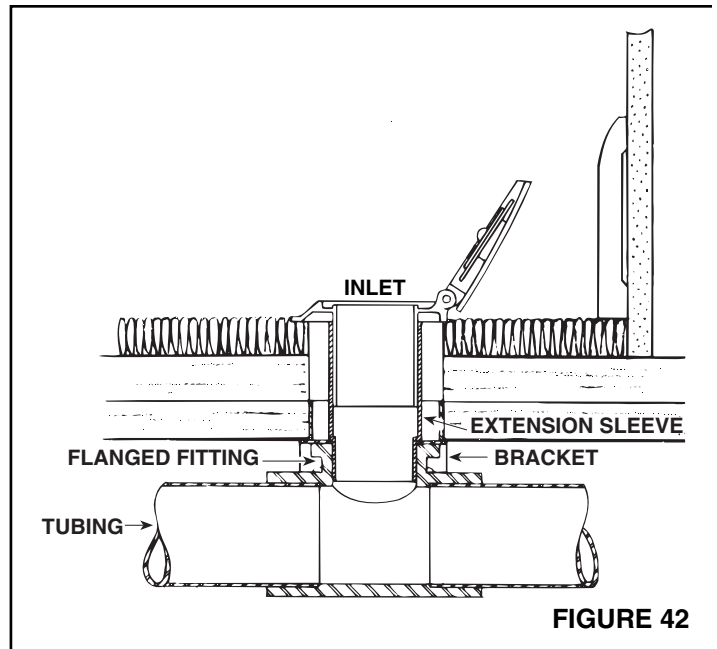
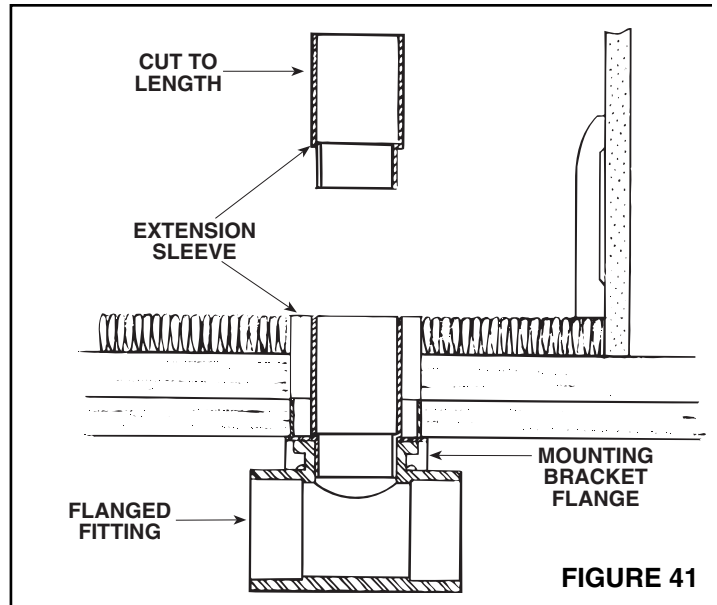
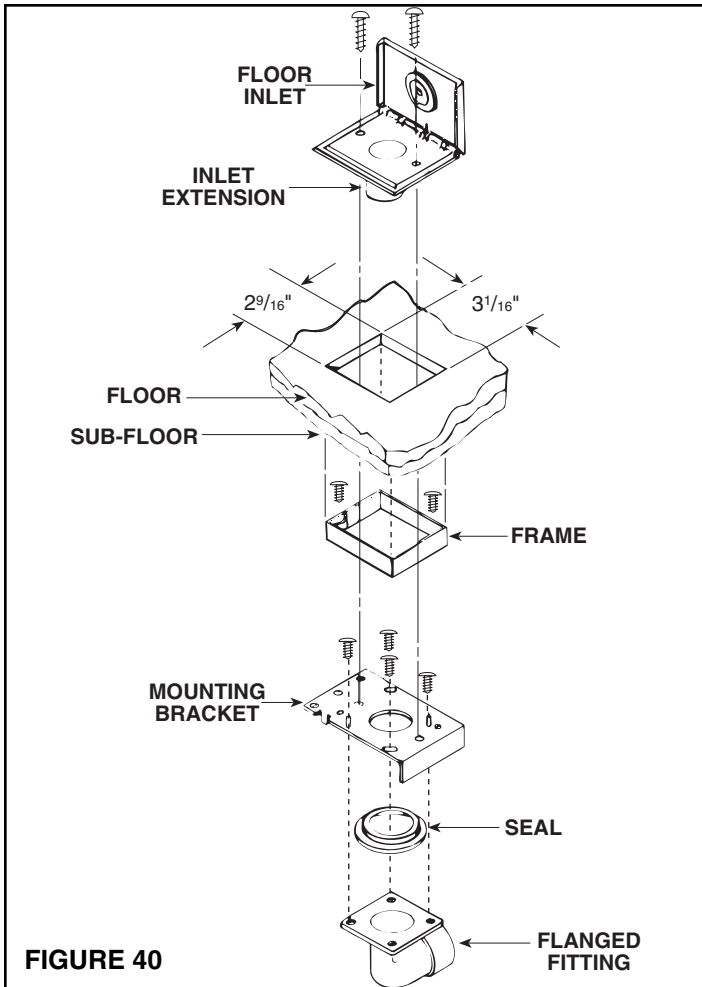

FIGURE 39

FLOOR INLET INSTALLATION



FINAL SYSTEM CHECK

Be sure all inlets are closed and soil bag is in place. Check switch on power unit for manual on/off operation.

Check each wall inlet to be sure contacts activate power unit when hose is inserted and switched on, if applicable. If Central Cleaning hose is not available at the time, a short piece of wire can be used to short contacts in wall inlet to activate power unit. Check each wall inlet and tubing connection for air leaks. Check power unit for leaks around inlet tube and dirt receptacle.

Make sure the filter bag is properly installed in the power unit according to directions printed on the bag or in homeowner's manual. Remove the extra bag and owner's manual from the

power unit dirt receptacle. It may be convenient to store them with the cleaning tools and accessories.

Now it's time to enjoy the benefits of a NuTone Central Cleaning System.

NuTone®

Two Year Limited Warranty

WARRANTY OWNER: NuTone warrants to the original consumer purchaser of its products that such products will be free from defects in materials or workmanship for a period of two (2) years from the date of original purchase. **THERE ARE NO OTHER WARRANTIES, EXPRESS OR IMPLIED, INCLUDING, BUT NOT LIMITED TO, IMPLIED WARRANTIES OF MERCHANTABILITY OR FITNESS FOR A PARTICULAR PURPOSE.**

During this two year period, NuTone will, at its option, repair or replace, without charge, any product or part which is found to be defective under normal use and service. **THIS WARRANTY DOES NOT EXTEND TO FLUORESCENT LAMP STARTERS OR TUBES, FILTERS, DUCT, ROOF CAPS, WALL CAPS AND OTHER ACCESSORIES FOR DUCTING.** This warranty does not cover (a) normal maintenance and service or (b) any products or parts which have been subject to misuse, negligence, accident, improper maintenance or repair (other than by NuTone), faulty installation or installation contrary to recommended installation instructions.

The duration of any implied warranty is limited to the one year period as specified for the express warranty. Some states do not allow limitation on how long an implied warranty lasts, so the above limitation may not apply to you.

NUTONE'S OBLIGATION TO REPAIR OR REPLACE, AT NUTONE'S OPTION, SHALL BE THE PURCHASER'S SOLE AND EXCLUSIVE REMEDY UNDER THIS WARRANTY. NUTONE SHALL NOT BE LIABLE FOR INCIDENTAL, CONSEQUENTIAL OR SPECIAL DAMAGES ARISING OUT OF OR IN CONNECTION WITH PRODUCT USE OR PERFORMANCE. Some states do not allow the exclusion or limitation of incidental or consequential damages, so the above limitation or exclusion may not apply to you. This warranty gives you specific legal rights, and you may also have other rights, which vary from state to state. This warranty supersedes all prior warranties.

WARRANTY SERVICE: To qualify for warranty service, you must (a) notify NuTone at the address stated below or telephone 1/800-543-8687, (b) give the model number and part identification and (c) describe the nature of any defect in the product or part. At the time of requesting warranty service, you must present evidence of the original purchase date.

Date of Installation

Builder or Installer

Model No. and Product Description

IF YOU NEED ASSISTANCE OR SERVICE:

For the location of your nearest NuTone Independent Authorized Service Center:

Residents of the contiguous United States Dial Free 1-800-543-8687

Please be prepared to provide:

Product model number • Date and Proof of purchase • The nature of the difficulty

Residents of Alaska or Hawaii should write to: NuTone Inc. Attn: Department of National Field Service, 4820 Red Bank Road, Cincinnati Ohio 45227-1599.

Residents of Canada should write to: Broan-NuTone Canada, 1140 Tristar Drive, Mississauga, Ontario, Canada L5T 1H9.

Rev. 03/2001

NuTone®

4820 Red Bank Road, Cincinnati, Ohio 45227
1140 Tristar Drive, Mississauga, Ontario, Canada L5T 1H9
www.nutone.com

NuTone Power Units covered by two-year warranty.
All other Central Cleaning products are warranted for one year from date of purchase.
Product specifications subject to change without notice.
Printed in U.S.A., Rev. 3/01, Part No. 35865