

Inside Remote Control

MODEL: IC-502 SERIES

Outdoor Remote Control

MODEL: IC-502LW SERIES

Use with NuTone IM-5000 and IM-5006
Selective Call Intercom System.

ROUGH-IN FRAME MOUNTING

The controls are mounted to the IR-91 Rough-In Frame.

New Construction

NOTE: Refer to the instructions packaged with the rough-in.

The IR-91 Frame is mounted to a wall stud during rough-in construction. The wiring is run to the control location. The control is mounted to the rough-in frame once the wall is in place.

Existing Construction

NOTE: Refer to the instructions packaged with the rough-in.

The IR-91 Frame requires a cutout to the finished wall. The Frame may be mounted either directly to a wall stud or between wall studs. The wiring is installed through the existing walls.

WIRING

RATING: INPUT 19vDC, 40mA

Refer to Figure 1. Connect the color-coded wires from the Master Station to the matching terminal screws on the speakers printed circuit board. CUT TERMINALS from the two (2) speaker wires and strip back 1/2" of insulation. Connect two (2) speaker wires to IW-2 wire (use wire nuts not supplied by NuTone) going to the speaker location.

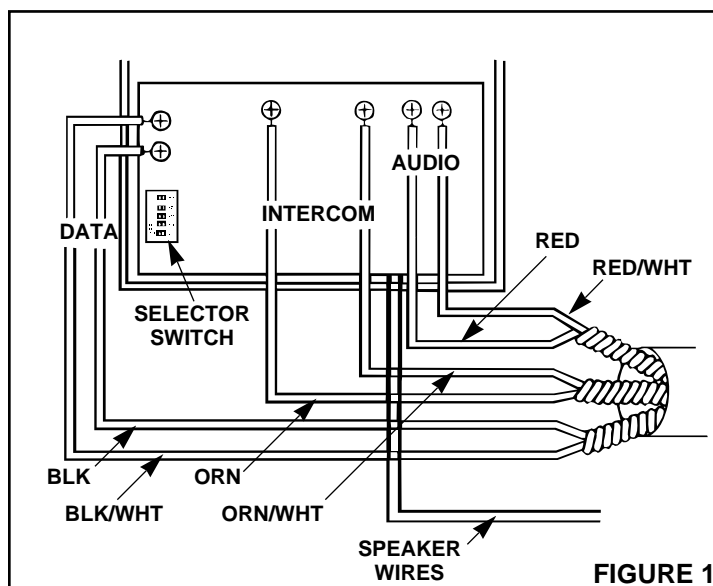

SETTING THE SELECTOR SWITCH

IMPORTANT: Be certain the system has been disconnected at the main power source prior to setting the selector switch. Powering the system up will allow the station identification to be effective.

IMPORTANT: The Master Station has been preset as Station #1. The remotes will be station 02 through 21 on the IM-5000 master and 02 through 25 on the IM-5006 master. Do not exceed 21 when using the IM-5000 or the IM-5000/401T power transformer will be damaged.

1. Refer to Figure 2. Locate the Selector Switch on the back of the remote control unit.
2. Refer to Figure 3. As indicated in Figure 3, set the Selector Switch in the ON and OFF positions.

MOUNTING

Refer to Figure 4.

1. Carefully place wires inside wall.
2. **IMPORTANT:** Outdoor models must be caulked with a waterproofing compound (Silicone Rubber, RTV or equivalent - not supplied by NuTone). Caulk across the top and both sides of the unit only; the bottom of the unit should not be caulked.
3. Using two mounting holes in the sides of the speaker body, secure the speaker to the frame with two (2) provided screws.

For operating instructions refer to the Radio-Intercom system's Operator's Manual. If Operator's Manual has been misplaced, write to: NuTone, Madison and Red Bank Roads, Cincinnati, Ohio 45227.

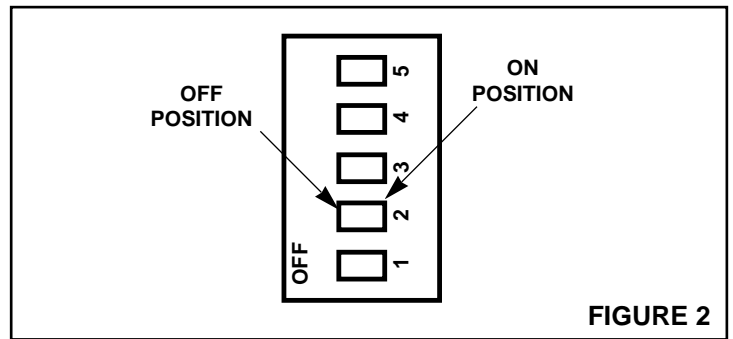

FIGURE 2

IF THE REMOTE UNIT IS TO BE THE STATION NUMBER:	THESE NUMBERS ON THE SELECTOR SWITCH MUST BE IN THE ON POSITION
02	2
03	1 & 2
04	3
05	1 & 3
06	2 & 3
07	1, 2 & 3
08	4
09	1 & 4
10	2 & 4
11	1, 2 & 4
12	3 & 4
13	1, 3 & 4
14	2, 3 & 4
15	1, 2, 3 & 4
16	5
17	1 & 5
18	2 & 5
19	1, 2 & 5
20	3 & 5
21	1, 3 & 5
22	2, 3 & 5
23	1, 2, 3 & 5
24	4 & 5
25	1, 4 & 5

FIGURE 3

NOTE: Shaded area is for IM-5006 only.

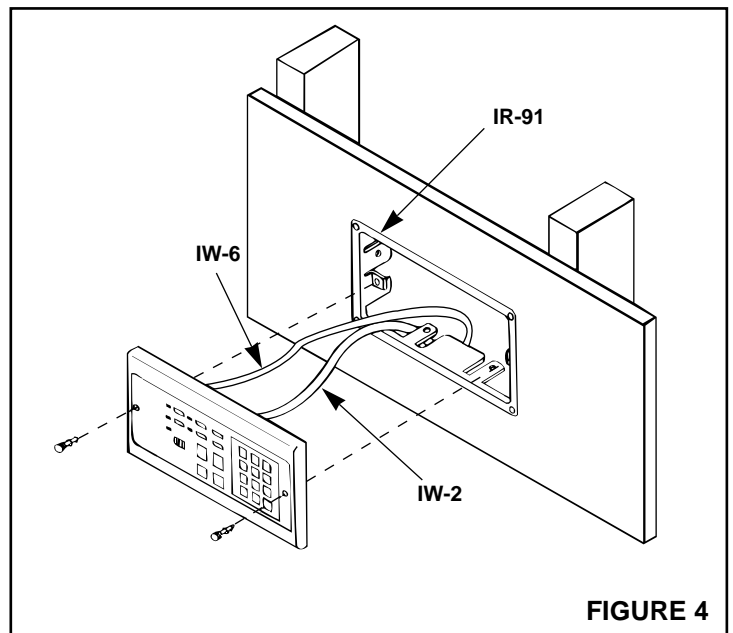

FIGURE 4

NuTone®

Two Year Limited Warranty

WARRANTY OWNER: NuTone warrants to the original consumer purchaser of its products that such products will be free from defects in materials or workmanship for a period of two (2) years from the date of original purchase. **THERE ARE NO OTHER WARRANTIES, EXPRESS OR IMPLIED, INCLUDING, BUT NOT LIMITED TO, IMPLIED WARRANTIES OF MERCHANTABILITY OR FITNESS FOR A PARTICULAR PURPOSE.**

During this two year period, NuTone will, at its option, repair or replace, without charge, any product or part which is found to be defective under normal use and service. **THIS WARRANTY DOES NOT EXTEND TO FLUORESCENT LAMP STARTERS OR TUBES, FILTERS, DUCT, ROOF CAPS, WALL CAPS AND OTHER ACCESSORIES FOR DUCTING.** This warranty does not cover (a) normal maintenance and service or (b) any products or parts which have been subject to misuse, negligence, accident, improper maintenance or repair (other than by NuTone), faulty installation or installation contrary to recommended installation instructions.

The duration of any implied warranty is limited to the one year period as specified for the express warranty. Some states do not allow limitation on how long an implied warranty lasts, so the above limitation may not apply to you.

NUTONE'S OBLIGATION TO REPAIR OR REPLACE, AT NUTONE'S OPTION, SHALL BE THE PURCHASER'S SOLE AND EXCLUSIVE REMEDY UNDER THIS WARRANTY. NUTONE SHALL NOT BE LIABLE FOR INCIDENTAL, CONSEQUENTIAL OR SPECIAL DAMAGES ARISING OUT OF OR IN CONNECTION WITH PRODUCT USE OR PERFORMANCE. Some states do not allow the exclusion or limitation of incidental or consequential damages, so the above limitation or exclusion may not apply to you. This warranty gives you specific legal rights, and you may also have other rights, which vary from state to state. This warranty supersedes all prior warranties.

WARRANTY SERVICE: To qualify for warranty service, you must (a) notify NuTone at the address stated below or telephone 1/800-543-8687, (b) give the model number and part identification and (c) describe the nature of any defect in the product or part. At the time of requesting warranty service, you must present evidence of the original purchase date.

Date of Installation

Builder or Installer

Model No. and Product Description

IF YOU NEED ASSISTANCE OR SERVICE:

For the location of your nearest NuTone Independent Authorized Service Center:

Residents of the contiguous United States Dial Free 1-800-543-8687

Please be prepared to provide:

Product model number • Date and Proof of purchase • The nature of the difficulty

Residents of Alaska or Hawaii should write to: NuTone Inc. Attn: Department of National Field Service, Madison and Red Bank Roads, Cincinnati Ohio 45227-1599.

Residents of Canada should write to: Broan-NuTone Canada, 1140 Tristar Drive, Mississauga, Ontario, Canada L5T 1H9.

Rev. 01/2000