

## In-Line Fans

### MODELS: ILF120, 130, 250

#### DESCRIPTION

- Remotely mounted fan reduces noise in occupied areas.
- Use with adjustable inlet grilles to control flow for any situation.
- Remote mounting provides flexibility in system design.
- High quality external rotor motor features long life, efficiency and quiet operation.
- Easy mounting to rafters or joist.
- Backward inclined centrifugal fan for strong air delivery with minimal noise.

#### DESIGN FEATURES

**Air Delivery:** **Model ILF120:** 110 CFM at .2" S.P.  
**Model ILF130:** 130 CFM at .2" S.P.  
**Model ILF250:** 250 CFM at .2" S.P.

**Sound Level:** N/A -unit is remotely mounted

**Material & Finish:**

**Housing:** Durable polycarbonate plastic

**Motor:** External rotor, ball bearing, 115 volts AC, 60Hz;

**ILF120** .37 amps.

**ILF130** .37 amps

**ILF250** .80 amps

**Blower Wheel:** Backward inclined centrifugal.

**Duct Size:** 4" diameter ILF120  
 5" diameter ILF130  
 6" diameter ILF250

#### INSTALLATION

- Not for use in cooking areas.
- Not for use in wet locations.
- Suitable for use with solid state speed controls.
- Housing mounts directly to bracket. Bracket mounts to rafter or joist..
- Complete installation instructions included with each unit.
- Switches and accessories available separately.

#### ARCHITECT'S SPECIFICATIONS

Exhaust Fan shall be Model ILF120, ILF130 or ILF250 as manufactured by NuTone according to listed specifications.

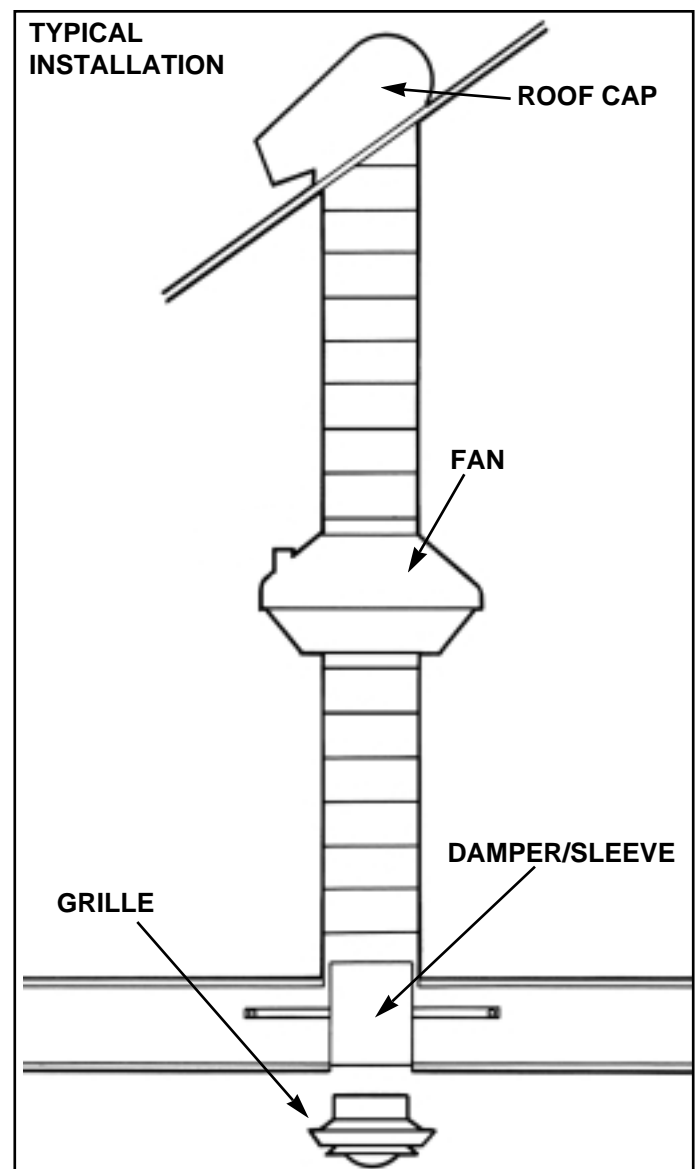
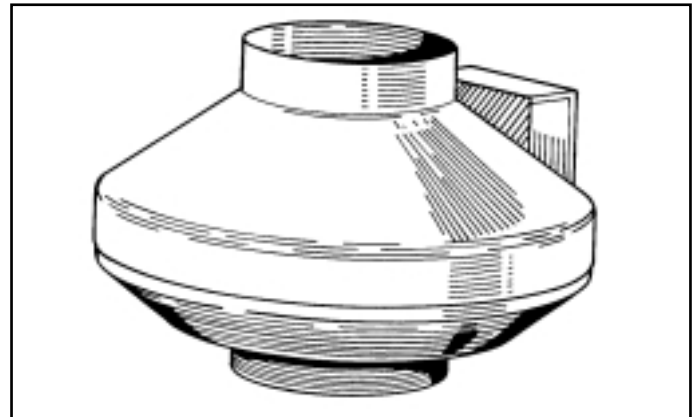

# CERTIFIED TEST DATA

Air delivery and sound level ratings are certified by the Home Ventilating Institute Division of AMCA, based on testing performed by an independent third party testing laboratory, in accordance with HVI standards. This NuTone model is listed by Underwriters' Laboratories Inc. and Certified by the Canadian Standards Association (CSA.)

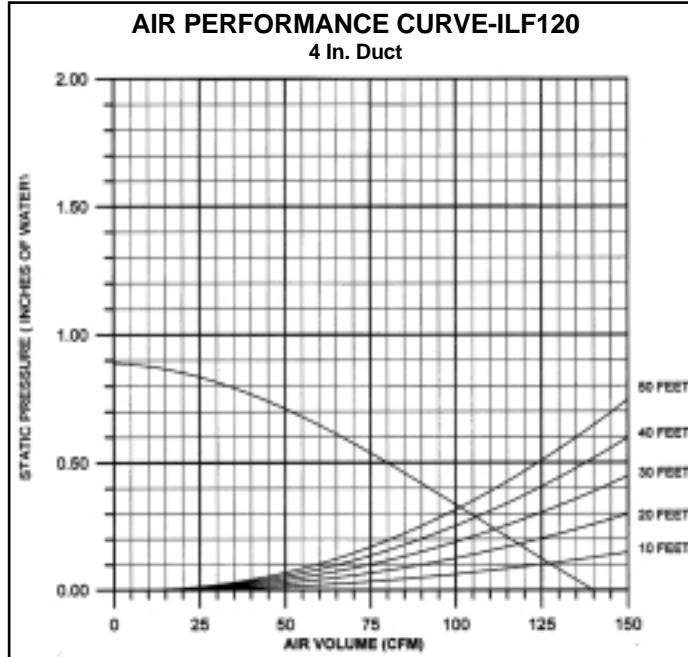

STATIC PRESSURE INCHES OF WATER	0.0	0.1	0.2	0.5	1.0	1.5	1.75
CFM	140	128	116	80	-	-	-

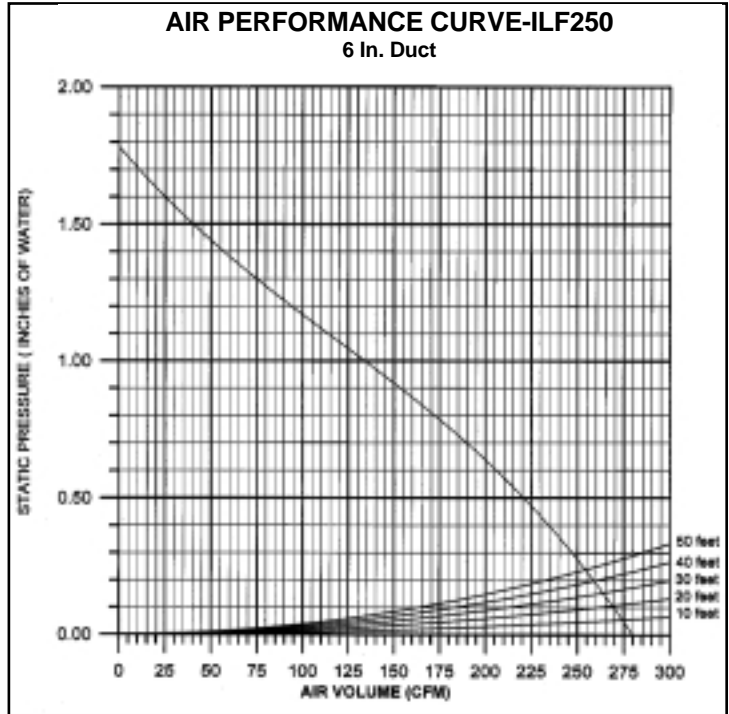

STATIC PRESSURE INCHES OF WATER	0.0	0.1	0.2	0.5	1.0	1.5	1.75
CFM	282	270	254	223	137	37	5

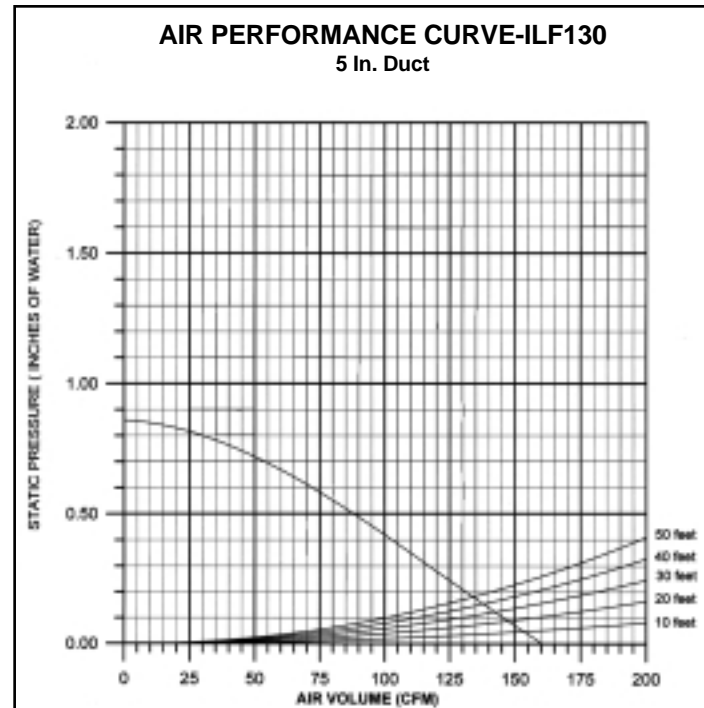

STATIC PRESSURE INCHES OF WATER	0.0	0.1	0.2	0.5	1.0	1.5	1.75
CFM	161	145	132	88	-	-	-

### The air delivery of a ventilating system may be determined by:

1. Determine the equivalent duct length for each 90 degree elbow by adding one foot of duct length for each inch of duct diameter, i.e., a 4 inch diameter duct elbow equals 4 feet equivalent duct length and an 8 inch diameter duct elbow equals 8 feet equivalent duct length.
2. Add the total straight length of duct and the equivalent length for each elbow to obtain the total equivalent duct length.
3. Locate the intersection of the fan performance curve and the total equivalent duct length curves and draw a vertical line down to the CFM scale and read the system air performance.

(NOTE: 3 1/4" x 10" duct equals 6 inch diameter duct.)

Product specifications subject to change without notice.