

In-Line Fans

MODELS: ILF360, ILF530

DESCRIPTION

- Remotely mounted fan reduces noise in occupied areas.
- High CFM, ideal for venting multiple areas.
- Use with adjustable inlet grilles to control flow for any situation.
- Remote mounting provides flexibility in system design.
- High quality external rotor motor features long life, efficiency and quiet operation.
- Easy mounting to rafters or joist.
- Backward inclined centrifugal fan for strong air delivery with minimal noise.

DESIGN FEATURES

Air Delivery: Model ILF360: 360 CFM at .2" S.P.

Model ILF530: 530 CFM at .2" S.P.

Sound Level: N/A -unit is remotely mounted

Material & Finish:

Housing: Durable polycarbonate plastic

Motor: External rotor, ball bearing, 115 volts AC, 60Hz;

ILF360 .87 amps.

ILF530 2.0 amps

Blower Wheel: Backward inclined centrifugal.

Duct Size: 8" diameter ILF360

10" diameter ILF530

INSTALLATION

- Not for use in cooking areas.
- Not for use in wet locations.
- Suitable for use over tubs and showers.
- Suitable for use with solid state speed controls.
- Housing mounts directly to bracket. Bracket mounts to rafter or joist.
- Complete installation instructions included with each unit.
- Switches and accessories available separately.

ARCHITECT'S SPECIFICATIONS

Exhaust Fan shall be Model ILF360 or ILF530 as manufactured by NuTone according to listed specifications.

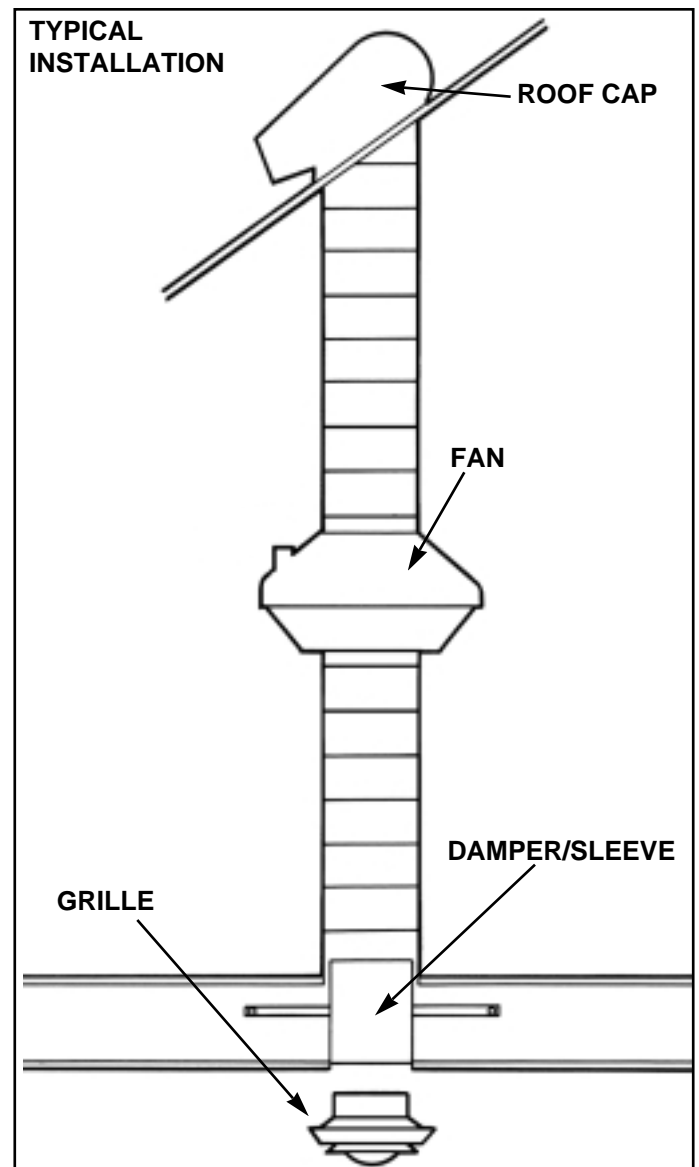
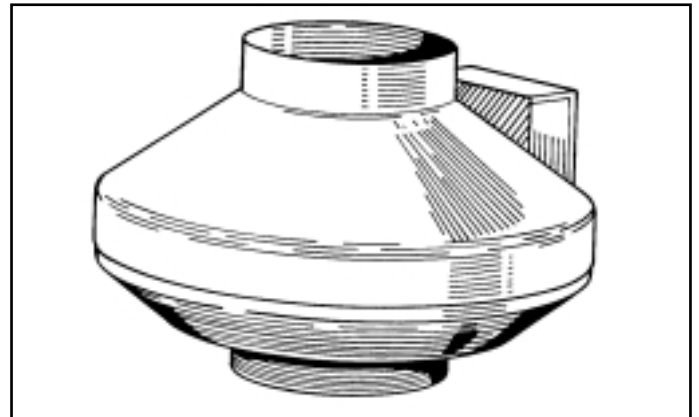

CERTIFIED TEST DATA

Air delivery and sound level ratings are certified by the Home Ventilating Institute Division of AMCA, based on testing performed by an independent third party testing laboratory, in accordance with HVI standards. This NuTone model is listed by Underwriters' Laboratories Inc. and Certified by the Canadian Standards Association (CSA.)

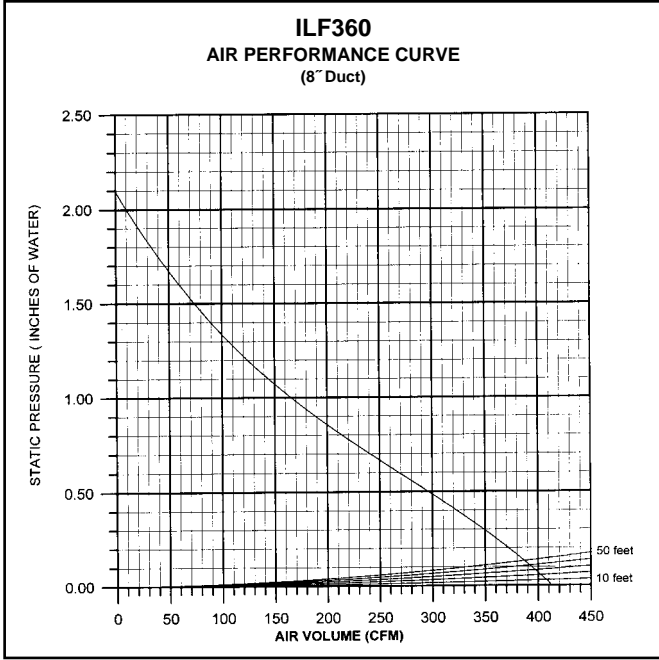

STATIC PRESSURE INCHES OF WATER	0.0	0.1	0.2	0.5	1.0	1.5	1.75
CFM	418	390	369	291	179	70	34

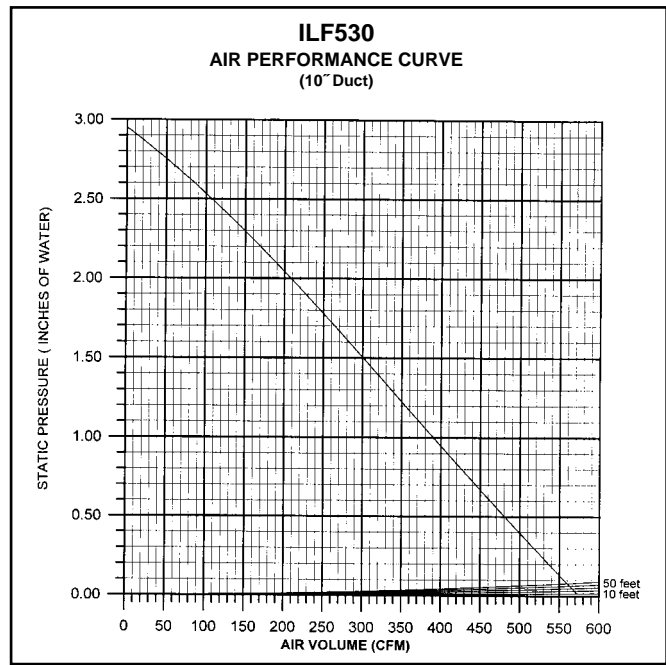

STATIC PRESSURE INCHES OF WATER	0.0	0.1	0.2	0.5	1.0	1.5	1.75
CFM	570	560	540	481	389	300	257

The air delivery of a ventilating system may be determined by:

1. Determine the equivalent duct length for each 90 degree elbow by adding one foot of duct length for each inch of duct diameter, i.e., a 4 inch diameter duct elbow equals 4 feet equivalent duct length and an 8 inch diameter duct elbow equals 8 feet equivalent duct length.
2. Add the total straight length of duct and the equivalent length for each elbow to obtain the total equivalent duct length.
3. Locate the intersection of the fan performance curve and the total equivalent duct length curves and draw a vertical line down to the CFM scale and read the system air performance.
(NOTE: 3 1/4" x 10" duct equals 6 inch diameter duct.)

Product specifications subject to change without notice.